

# TITAN

## 26 cm<sup>3</sup> 5 in 1 Multi Tool

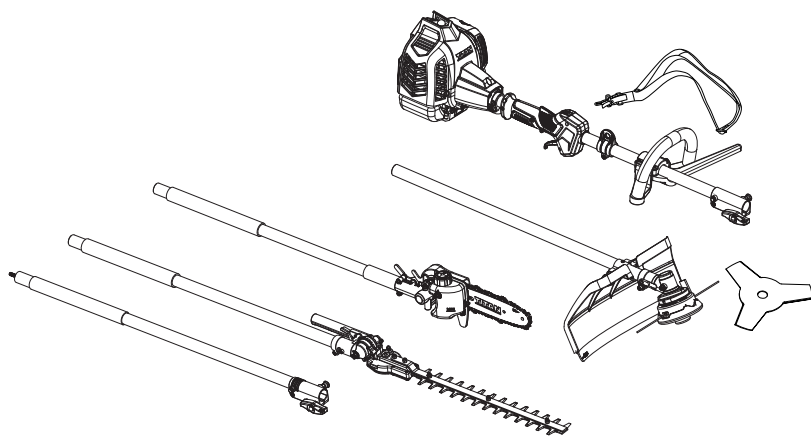

Original Instructions – TT5MTP26-2\_\_V10522

# TT5MTP26-2

BX220IM/B3

EAN: 5059340256061



**WARNING:** Read the instruction handbook thoroughly before using the machine. First time operators should receive practical use instructions of the machine and protective equipment from an experienced operator.

# Let's get started...

These instructions are for your safety. Please read through them thoroughly before use and retain them for future reference.



## Getting **Started...** 02

<b>Safety</b> information	03
<b>Technical</b> specifications	14
<b>Your 5-in-1 Multi tool</b>	17
<b>Before you start</b>	21
<b>Quick start</b>	37



## In more **detail...** 39

<b>Machine</b> functions	39
<b>Operation</b>	42
<b>Care and maintenance</b>	55
<b>Troubleshooting</b>	69
<b>Recycling and disposal</b>	72
<b>Guarantee</b>	72
<b>Customer care and technical helpline</b>	73
<b>Availability of spare parts</b>	74
<b>UK declaration of conformity</b>	75
<b>EU declaration of conformity</b>	76

## Safety warnings

### IMPORTANT READ CAREFULLY BEFORE USE KEEP FOR FUTURE REFERENCE

- > This machine is not intended for use by children and persons with reduced physical, sensory or mental capabilities, or lack of experience and knowledge.
- > Children should be supervised to ensure that they do not play with the machine.



**WARNING!** Your safety and the safety of others is very important. Of course, it is not practical or possible to warn you about all the hazards associated with operating or maintaining this machine. At all times you must use your own good judgment.

### Training

Read the instructions carefully. Be familiar with the controls and the proper use of the machine.

### Preparation

- > Never allow children or people unfamiliar with these instructions to use the machine. Local regulations can restrict the age of the operator.
- > Keep bystanders and pets at a safe distance from the work area. Never operate the machine while people, especially children, or pets are nearby.
- > Keep in mind that the operator or user is responsible for accidents or hazards occurring to other people or their property.
- > Wear ear protection and safety glasses at all times while operating the machine.
- > Always wear substantial footwear and long trousers while operating the machine. Do not operate the machine when barefoot or wearing open sandals.
- > **WARNING - Petrol is highly flammable.**
  - store fuel in containers specifically designed for this purpose,
  - refuel outdoors only and do not smoke while refuelling,
  - add fuel before starting the engine. Never remove the cap of the fuel tank or add petrol while the engine is running or when the engine is hot,
  - if petrol is spilled, do not attempt to start the engine but move the machine away from the area of spillage and avoid creating any source of ignition until petrol vapours have dissipated.
- > Replace all fuel tanks and bottle caps securely.
- > Do not attempt to tackle any job that you are not adequately trained for.
- > Do not operate the machine if it has faulty safety equipment or damaged parts.

- > Do not under any circumstances modify the machine. Modifications can result in serious personal injury or death.
- > Servicing and maintenance, other than listed in this manual, should be performed by an authorised service centre.
- > First time user should have practical instruction in the use of the machine and protective equipment from an experienced operator.
- > National regulation can restrict the use of the machine.

### **Clothing and personal protective equipment (PPE)**

- > Secure long hair so that they are above the shoulder level.
- > Do not wear loose fitting clothing or jewellery as those could be drawn into the engine or catch a moving part of the machine.
- > Use the following safety clothing and personal protective equipment (PPE) when operating the machine:
  - Wear head protection (compliant to EN 397)
  - Wear hearing/ear protection (compliant to EN 352-1)
  - Wear eye protection (compliant to EN 166)
  - Wear protective gloves (compliant to EN ISO 21420 Class 0)
  - Wear protective clothing (compliant to EN ISO 11393-2, EN ISO 13688 Class 1)
  - Wear protective and slip-resistant footwear (compliant to EN ISO 20345 Class 2)
  - First Aid Kit in case of injury
  - Dry powder fire extinguisher readily available

### **Operation**

- > Keep all parts of the body away from the machine when the machine is operating. Before starting the engine, make sure the machine is not contacting any objects and is free from obstructions. A moment of inattention while operating the machine may cause entanglement of your clothing or body.
- > Keep bystanders and animals at least 15 metres away from the machine.
- > Keep the machine a sufficient distance of at least 15 metres away from electrical power lines.
- > Beware of thrown objects. Objects thrown by the machine could hit the operator or other bystanders. Always ensure that other people and pets remain at a safe distance from the machine when it is in operation.
- > Always ensure that all handles and guards are fitted properly before operating the machine. Never attempt to use an incomplete machine or one fitted with unauthorized parts.
- > Do not lean too far forward while using the machine. Ensure you are standing firmly and keep your balance at all times. Use the supplied harness to spread the weight evenly on the body.
- > Do not operate the machine with one hand! Serious injury to the operator or bystanders may result from one handed operation.



- > Keep handles dry, clean and free from oil and grease. Greasy, oily handles are slippery and may cause loss of control.
- > Do not operate the machine if you are tired or ill, under the influence of drugs, alcohol or medication.
- > When the machine is switched off, make sure the cutting attachment has stopped before setting down the machine.
- > Do not operate the engine in a confined space where dangerous carbon monoxide fumes can collect.
- > Operate the machine only in daylight or in good artificial light.
- > Do not touch any moving parts before they have come to a complete stop.
- > Operate the machine in a recommended position and only on a firm, level surface.
- > Never operate the machine on a ladder or other insecure support.
- > Operate the machine only at reasonable hours – not early in the morning or late at night when people might be disturbed.
- > Make sure that the ventilation openings are kept clear of debris.
- > Make sure that the air intake of the combustion engine is clear. Keep the air intake free of dust, dirt particles, gases and fumes.
- > Never use the machine without the air filter installed.
- > Check for signs of wear or damage before each use, after any impact or if the machine has been dropped. Repair the machine if necessary.
- > Stop the engine, disconnect the spark plug connector:
  - before clearing blockages;
  - before cleaning or servicing the machine;
  - after striking a foreign object. Inspect the machine for damage and make repairs before restarting and operating the machine;
  - if the machine starts to vibrate abnormally (check immediately);
  - whenever you leave the machine unattended;
  - before refuelling.

### **Additional safety warnings for brush cutter and grass trimmer**

- > Before starting the engine, make sure the cutting attachment is not contacting any objects.
- > Thoroughly inspect the area where the machine is to be used and remove all stones, sticks, wires, bones and other foreign objects.
- > Avoid operating the machine in wet grass or take additional precautions to avoid slipping.
- > When operating on a slope, always stand at a lower level than the machine. Never cut or trim on an icy, slippery hill or slope.
- > Do not operate the cutting attachment when crossing surfaces other than grass, and when transporting the machine to and from the working area.
- > Take care against injury from a cutter fitted for trimming the cutting line length. After extending the cutter line always return the machine to its normal operating position before switching on.

- > If the cutting mechanism does not stop when the engine idles, switch the engine off and stop using the machine. Then contact the authorised service centre.
- > Do not operate the machine with a damaged or excessively worn cutting attachment.
- > Do not operate the machine with cutting attachments other than provided. Do not use with saw blades or flail blades.
- > Beware of blade thrust! Machines fitted with blades can be thrown violently to the side when the blade comes into contact with a fixed object. A blade is capable of amputating an arm or leg.

### **Additional safety warnings for pole pruner**

- > Before starting the engine, make sure the saw chain is not contacting any objects.
- > Keep all parts of your body away from the saw chain. Do not hold material to be cut when the machine is operating. Stop the engine before clearing jammed material. One moment of inattention while operating the machine may result in a serious personal injury.
- > To avoid injuries due to falling branches, do not stand under the branches that you want to cut off. Be aware of branches that may spring back and cause injuries. Work at an angle of approximately 60°.
- > Keep an eye not only on the branches being cut, but also on falling material, to avoid tripping.
- > Do not cut any wood that is lying on the ground and do not attempt to saw roots that are protruding from the soil. Avoid immersing the saw chain in the soil at all costs, as this could blunt the saw chain.

### **Additional safety warnings for hedge trimmer**

- > Before starting the engine, make sure the cutter blades are not contacting any objects.
- > Keep all parts of your body away from the cutter blade. Do not cut material or hold material to be cut when the machine is operating. Stop the engine before clearing jammed material. One moment of inattention while operating the machine may result in a serious personal injury.
- > While trimming, ensure not to come into contact with objects such as fence wire or plant supports. This could cause damage to the cutter blades. Inspect the hedge to be cut carefully and remove any wires or other foreign objects.
- > After changing the working angle, check whether both lock levers have clicked firmly into place. If one of the lock levers remains open, the second could be unintentionally be released by a branch and the cutter blade could swing down causing injuries.

### **Maintenance**

- > Keep all nuts, bolts and screws tight to be sure the machine is in a safe working condition.
- > Disconnect the spark plug connector before performing maintenance, except for carburetor adjustments.
- > Keep the engine and petrol storage area free of grass, thatch, moss, leaves or excessive grease to reduce the fire hazard.

- > Examine the machine before each use and replace worn or damaged parts.
- > Replace fuel lines and fuel filters every 2 years.

### Fuel handling

- > Always switch the machine off, disconnect the spark plug connector and let the machine cool down before refuelling it.
- > Fuel and fuel vapour are highly flammable. Take care when handling fuel.
- > Do not smoke while operating the machine, handling fuel or near fuel.
- > Always use suitable aids such as funnels and filler necks. Do not spill any fuel on the machine or its exhaust system. There is a risk of ignition. Remove spilled fuel carefully from all parts of the machine. Any residue which may be present must have completely volatilised, before the machine is put into operation!
- > Never refuel indoors.
- > Never use the machine in environments where there is a risk of explosion. Exhaust gases and fuel fumes are noxious. Fuel fumes can ignite.
- > Avoid skin contact with petrol.
- > Do not eat or drink, while you are refuelling the machine. If you have swallowed petrol or oil, or if petrol or oil has got into your eyes, then seek the advice of a doctor immediately.
- > Tighten the fuel tank cap thoroughly after refilling the fuel tank.
- > Fuel vapour pressure may build up inside the fuel tank depending on the fuel used, weather conditions and the tank venting system. To reduce the risk of burns and other personal injuries, remove the fuel tank cap carefully to allow any pressure build up to release slowly.
- > Ensure the spark plug connector is secure after refilling the fuel tank. Loose connector may cause electrical arcing that could ignite combustible fumes and cause a fire or explosion.
- > Use caution when handling fuel. To avoid any accidental fires, move the machine at least 3 metres from the fuelling point before starting the engine.
- > Do not operate the machine if it is leaking fuel.
- > Do not remove the fuel tank cap while the engine is running.
- > Do not store cans of fuel or refill the fuel tank in any place where there is a boiler, stove, wood fire, electrical sparks, welding sparks, or other sources of heat or fire which might ignite the fuel.
- > If any fuel spillage occurs during refuelling, use a dry rag to wipe up spills and allow remaining fuel to evaporate before starting the engine on again.
- > If you have spilt fuel on yourself or on your clothes, change your clothes and wash any part of your body that has come in contact with fuel before turning the engine on again.
- > If fuel has ignited, put out the fire with a dry powder fire extinguisher.
- > Never breathe in any fuel fumes, when you are refuelling the machine.
- > Keep fuel fresh (less than 30 days) or add fuel stabiliser.

### Transport and storage

- > Stop the engine before transporting the machine.
- > Carry the machine by the handle with the engine off. Handling the machine properly reduces the possibility of personal injury.
- > Refit the transport guard on the cutting attachments (cutting blade and saw chain) during transportation or storage.
- > Allow the engine to cool before storing in any enclosure.
- > Never store the machine with petrol in the tank inside a building where fumes can reach an open flame or spark.
- > Store the machine and fuel so that there is no risk of leakages or fumes coming into contact with sparks or naked flames from electrical equipment, electric motors, relays/switches, boilers etc.
- > Empty machine of fuel after every use. Run the machine dry of fuel in idle before storage.
- > Dispose of waste oil and fuel at a local petrol station, local authority centre or where facilities exist.

### Vibration and noise reduction

**To reduce the impact of noise and vibration emission, limit the time of operation, use low-vibration and low-noise operating modes as well as wear personal protective equipment.**

Take the following points into account to minimise the vibration and noise exposure risks:

- > Only use the machine as intended by its design and these instructions.
- > Ensure that the machine is in good condition and well maintained.
- > Use correct attachments for the machine and ensure they are in good condition.
- > Keep a tight grip on the handles/gripping surfaces.
- > Maintain this machine in accordance with these instructions and keep it well lubricated (where appropriate).
- > Plan your work schedule to spread any high vibration tool use across a longer period of time.

## Emergency

**Familiarise yourself with the use of this machine by means of this instruction manual. Memorise the safety directions and follow them to the letter. This will help to prevent risks and hazards.**

- > **Always be alert when using this machine, so that you can recognise and handle risks early.** Fast intervention can prevent serious injury and damage to property.
- > **Stop the engine and disconnect the spark plug connector if there are malfunctions.** Have the machine checked by a qualified professional and repaired, if necessary, before you operate it again.
- > **In case of fire stop the engine and disconnect the spark plug connector.** Take fire-extinguishing measures immediately if the machine switch is no longer accessible.



**WARNING!** Never use water to extinguish the machine on fire. Burning fuel must be extinguished with special extinguishing agents! We recommend that you keep a suitable fire extinguisher within reach in your work area! We recommend to have dry powder fire extinguisher always available.

## Residual risks

**Even if you are operating this machine in accordance with all the safety requirements, potential risks of injury and damage remain. The following dangers can arise in connection with the structure and design of this machine:**

- > Health defects resulting from vibration emission if the machine is used over long periods of time or not adequately managed and properly maintained.
- > Injuries and damage to property due to broken application tools or the sudden impact of hidden objects during use.
- > Danger of injury and property damage caused by flying objects.
- > Burns, if touching hot surfaces.





**WARNING!** This machine produces an electromagnetic field during operation! This field may under some circumstances interfere with active or passive medical implants! To reduce the risk of serious or fatal injury, we recommend persons with medical implants to consult their doctor and the medical implant manufacturer before operating this machine!

## Symbols

On the machine, the rating label and within these instructions you will find among others the following symbols and abbreviations. Familiarise yourself with them to reduce hazards like personal injuries and damage to property.

kW	Kilowatt	l	Litre
cm <sup>3</sup>	Cubic centimetre	ml	Millilitre
min <sup>-1</sup>	Per minute	°C	Degree Celsius
m	Metre	dB(A)	Decibel (A-rated)
mm	Millimetre	m/s <sup>2</sup>	Metres per second squared
cm	Centimetre	kg/h	Kilogram per hour
kg	Kilogram	g/kWh	Gram per kilowatt per hour
yyWxx	Manufacturing date code; year of manufacturing (20yy) and week of manufacturing (Wxx)		

### Description of signal words:

-  **DANGER!** The signal word that indicates a hazard with a high level of risk which, if not avoided, will result in death or serious injury.
-  **WARNING!** The signal word that indicates a hazard with a medium level of risk which, if not avoided, could result in death or serious injury.
-  **CAUTION!** The signal word that indicates a hazard with a low level of risk which, if not avoided, could result in minor or moderate injury.
- NOTE!** Indicates a practical tip, advice or practice not related to personal injury.



Warning! Read the instruction handbook and follow all the warnings and safety instructions.



Note/Remark.



Read the instruction handbook.



Wear protective gloves (compliant to EN ISO 21420 Class 0)



Wear hearing/ear protection (compliant to EN 352-1)  
Wear eye protection (compliant to EN 166)  
Wear head protection (compliant to EN 397)



Wear protective and slip-resistant footwear (compliant to EN ISO 20345 Class 2)



Wear protective clothing  
(compliant to EN ISO 11393-2, EN ISO 13688 Class 1)



Stop the engine before refuelling. Never refuel the machine while the engine is running.

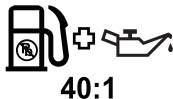

Only refuel unleaded petrol and oil mixture in ratio 40:1. Do not use any other mixture ratio.



Open flames in the work area, around the machine and in the vicinity of flammable materials are prohibited!



Do not smoke in the work area, around the machine and in the vicinity of flammable materials!



Risk of fire/flammable materials.



Hot surface, do not touch! High temperatures on the machine's surfaces and structural parts that could cause burns, if they are touched. The machine can also stay hot for a longer period of time after the operation!



Stop the engine and disconnect the spark plug connector before assembly, cleaning, adjustments, maintenance, storage and transportation.

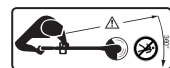

Keep bystanders out of working area during operation. A distance of at least 15 metres around the operator must be observed.





Beware of thrown objects. Objects thrown by the machine could hit the operator or other bystanders. Always ensure that other people and pets remain at a safe distance from the machine when it is in operation.



Beware of blade thrust! Machines fitted with blades can be thrown violently to the side when the blade comes into contact with a fixed object. Blade is capable of amputating an arm or leg.



Do not touch the cutting attachment until it stops completely.



Press the primer 6 times before starting the cold engine.



Filling for saw chain oil.



Direction of the saw chain.

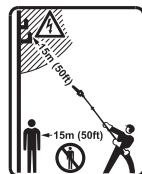

Keep the pole pruner a sufficient distance away from electrical power lines. Keep at least 15 metres distance from the electrical power lines.



Risk of loose clothing being drawn into air intake.



Risk of long hair being drawn into air inlet.



Maximum rotational frequency of the shaft for the cutting attachment in  $\text{min}^{-1}$ .

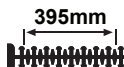

Max. cutting length of the cutter blades in mm.





Max. cutting capacity of the cutter blades in mm.



Diameter of the brush cutting blade in mm.



Max. cutting width of the trimmer head in cm.



Max. cutting length of the pole pruner guide bar in mm.

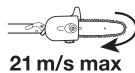

Max. rotational frequency of pole pruner in m/s.



Product weight in kg.



Choke – CLOSE position.



Choke – OPEN position.



Guaranteed sound power level value in dB.



The machine complies with the applicable European directives and an evaluation method of conformity for these directives was done.



The machine complies with the conformity requirements of the applicable UK regulations.

Designation of the tool

TT5MTP26-2

(TT\_Brand Name - Titan; 5MT\_5 in 1 Multi Tool; P\_Petrol Power; 26\_Engine Size)

## Technical specifications

### ENGINE

- > **Engine type:** SL34G, air cooled 2 stroke
- > **Engine displacement:** 26 cm<sup>3</sup> (26 cc)
- > **Maximum engine power (in accordance with ISO 8893):** 0.75 kW
- > **Maximum operating engine speed (rotational frequency):** 10000 min<sup>-1</sup>
- > **Idle speed:** 2700 – 3300 min<sup>-1</sup>
- > **Clutch engagement speed:** 5080 min<sup>-1</sup>
- > **Fuel tank volume:** 460 cm<sup>3</sup> (ml)
- > **Fuel type:** Octane rating of at least 90, unleaded, maximum 10% renewable ethanol (E10 or below)
  
- > **Fuel consumption (in accordance with ISO 8893) at max. engine performance:** 0.4 kg/h
- > **Specific fuel consumption (in accordance with to ISO 8893) at max. engine performance:** 533 g/kWh
- > **Engine oil type:** Top quality synthetic oil specifically for two-stroke engines, of JASO FC minimum specification.
  
- > **Mixture ratio petrol:oil:** 40:1
- > **Spark plug type:** CHAMPION RCJ6Y
- > **Spark plug gap:** 0.6 – 0.7 mm
- > **Weight (without fuel, cutting attachment, guard and harness):** approx. 4.7 kg

### BRUSH CUTTER

- > **Weight (empty tank):** 6.6 kg
- > **Blade Size:** 3 teeth, Ø255 x Ø25.4 mm
- > **Maximum rotational frequency of the spindle:** 8000 min<sup>-1</sup>

### GRASS TRIMMER

- > **Weight (empty tank):** 6.3 kg
- > **Line spool diameter:** Ø2.4 mm
- > **Max. cutting width:** Ø430 mm
- > **Maximum rotational frequency of the spindle:** 7000 min<sup>-1</sup>

**HEDGE TRIMMER**

- > **Weight (empty tank):** 6.9 kg
- > **Max. cutting length:** 395 mm
- > **Teeth gap:** 24 mm
- > **Reciprocating speed:** 2500 min<sup>-1</sup>
- > **Adjustable cutting angle range:** -90° to +60°

**POLE PRUNER**

- > **Weight (empty tank):** 6.5 kg
- > **Chain oil tank:** 150 cm<sup>3</sup> (ml)
- > **Saw chain speed:** max. 21 m/s
- > **Max. cutting length:** 180 mm (7")
- > **Guide bar length:** 203 mm
- > **Guide bar type:** M1500833-1041TL, Trilink
- > **Saw chain type:** CL15033X 3/8", Trilink
- > **Chain pitch:** 9.525 mm (3/8")
- > **Chain gauge (thickness of drive links):** 1.27 mm (0.050")
- > **Drive sprocket (teeth and pitch):** 7 teeth x 9.525 mm (3/8")
- > **Adjustable cutting angle range:** 0° to +90°

**Sound levels**

**Equivalent sound pressure level at operator position determined in accordance with ISO 22868**

- > **Brush cutter  $L_{pA av}$ :** 93.6 dB(A)
- > **Grass trimmer  $L_{pA av}$ :** 92.7 dB(A)
- > **Hedge trimmer  $L_{pA av}$ :** 92.4 dB(A)
- > **Pole pruner  $L_{pA av}$ :** 92.6 dB(A)
- >  **$K_{pA}$  uncertainty:** 3 dB(A)

**Sound power level determined in accordance with ISO 22868 and Directive 2000/14/EC**

**Brush cutter**

- > **Measured max.  $L_{WA}$ :** 108.4 dB(A)
- >  **$K_{WA}$  uncertainty:** 1.92 dB(A)

**Grass trimmer**

- > **Measured max.  $L_{WA}$ :** 105.8 dB(A)
- >  **$K_{WA}$  uncertainty:** 1.92 dB(A)

**Hedge trimmer**

- > **Measured max.  $L_{WA}$ :** 107.3 dB(A)
- >  **$K_{WA}$  uncertainty:** 1.92 dB(A)

**Pole pruner**

- > **Measured max.  $L_{WA}$ :** 108.1 dB(A)
- >  **$K_{WA}$  uncertainty:** 1.92 dB(A)
- > **Guaranteed sound power level  $L_{WA}$   
(acc. to 2000/14/EC amended  
by 2005/88/EC):** 110 dB(A)

**Equivalent vibration total value determined in accordance with ISO 22867**

- > **Brush cutter (front handle):** 7.15 m/s<sup>2</sup>
- > **Brush cutter (rear handle):** 8.05 m/s<sup>2</sup>
- > **Grass trimmer (front handle):** 6.06 m/s<sup>2</sup>
- > **Grass trimmer (rear handle):** 6.75 m/s<sup>2</sup>
- > **Hedge trimmer (front handle):** 8.80 m/s<sup>2</sup>
- > **Hedge trimmer (rear handle):** 10.33 m/s<sup>2</sup>
- > **Pole pruner (front handle):** 9.91 m/s<sup>2</sup>
- > **Pole pruner (rear handle):** 11.14 m/s<sup>2</sup>
- > **K uncertainty:** 1.5 m/s<sup>2</sup>

The sound values have been determined according to noise test code given in ISO 10884 and ISO 22867, using the basic standards ISO 22868.

Wear hearing protection, especially when sound pressure is over 80 dB(A).

The declared vibration value has been measured in accordance with a standard test method (according to EN ISO 11680-1 / EN ISO 10517/ EN ISO 11806-1) and may be used for comparing one machine with another. The declared vibration value may also be used to evaluate the exposure for the user caused by vibration in advance.



**WARNING!** Depending on the actual use of the machine the vibration values can differ from the declared total. Adopt proper measures to protect yourself against vibration exposures. Take the whole work process including times the machine is running under no load or switched off into consideration! Proper measures include among others regular maintenance and care of the machine and accessories, keeping hands warm, periodical breaks and proper planning of work processes!

## A. Main unit

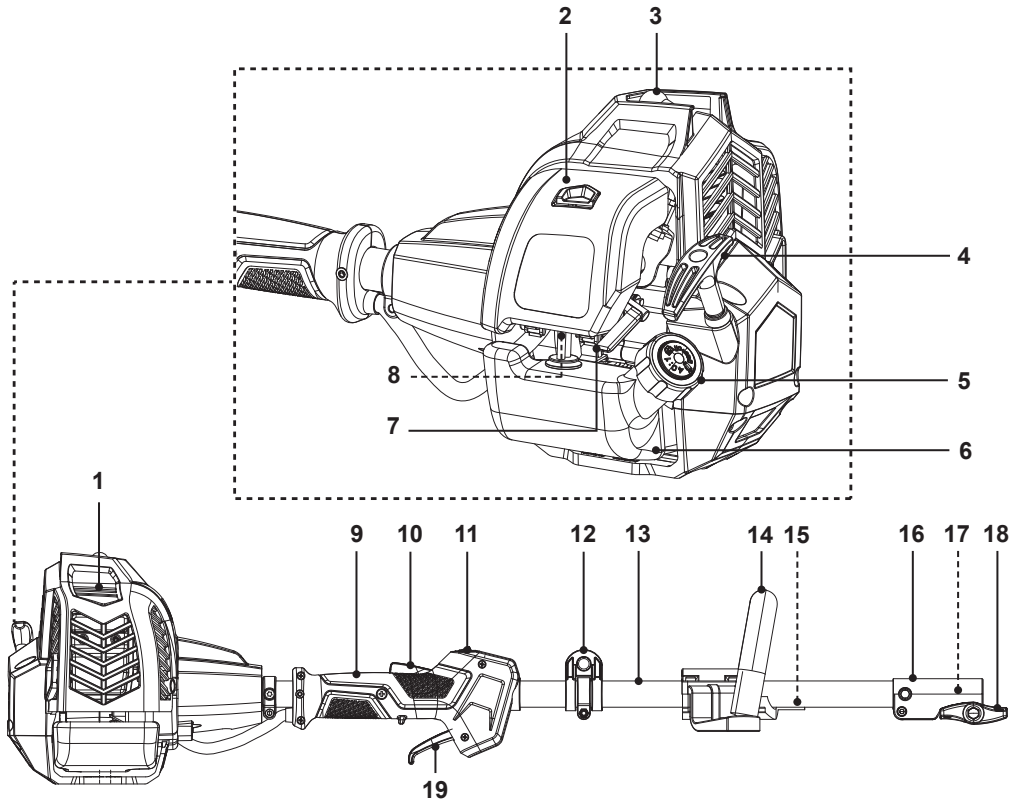

- |                              |                            |
|------------------------------|----------------------------|
| 1. Power unit                | 11. Stop switch            |
| 2. Air filter case           | 12. Harness loop           |
| 3. Spark plug connector      | 13. Upper drive shaft tube |
| 4. Recoil starter handle     | 14. Front handle           |
| 5. Fuel tank cap             | 15. Barrier bar            |
| 6. Fuel tank                 | 16. Shaft clamp            |
| 7. Choke                     | 17. Locking knob           |
| 8. Primer                    | 18. Locking nut            |
| 9. Rear Handle               | 19. Throttle trigger       |
| 10. Throttle trigger lockout |                            |

### B. Hedge trimmer attachment

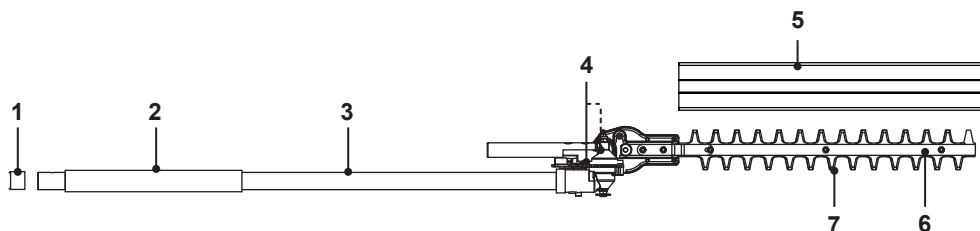

- |                   |                    |
|-------------------|--------------------|
| 1. Protection cap | 5. Transport guard |
| 2. Hand-grip      | 6. Cutting device  |
| 3. Shaft tube     | 7. Cutter blade    |
| 4. Locking levers |                    |

### C. Pole pruner attachment

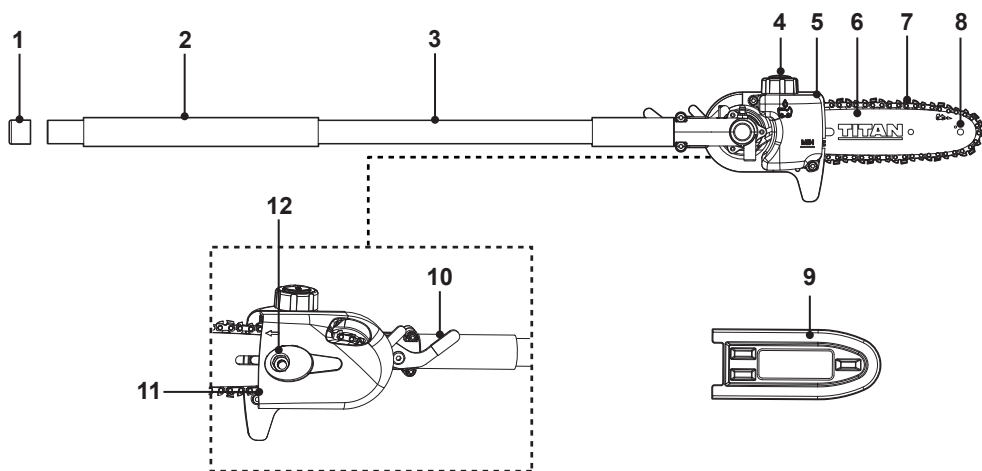

- |                   |                     |
|-------------------|---------------------|
| 1. Protection cap | 7. Saw chain        |
| 2. Hand-grip      | 8. Lubrication hole |
| 3. Shaft tube     | 9. Guide bar cover  |
| 4. Oil filler cap | 10. Locking lever   |
| 5. Oil tank       | 11. Clutch cover    |
| 6. Guide bar      | 12. Fixing nut      |

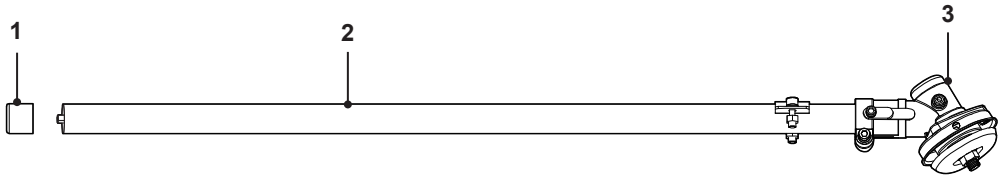
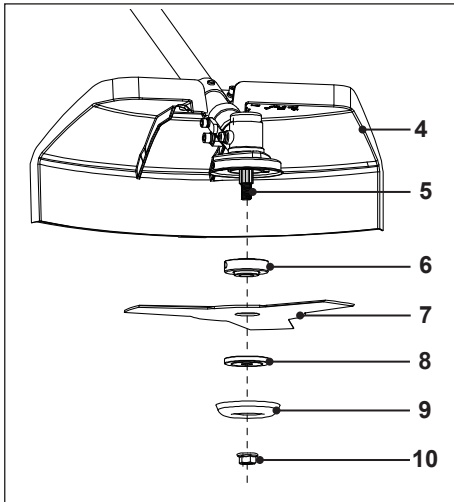
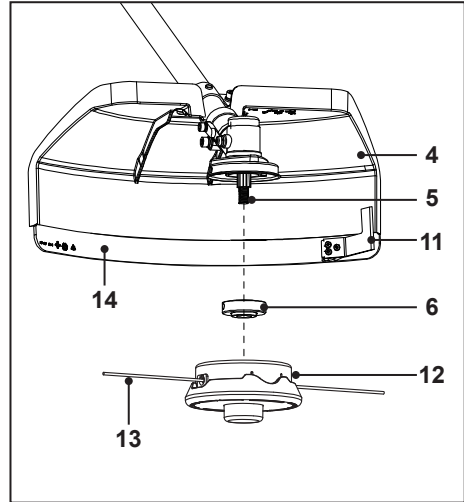
**D. Brush cutter/grass trimmer****Brush cutter assembly****Grass trimmer assembly**

1. Protection cap
2. Shaft tube
3. Gear head
4. Cutting-attachment guard
5. Spindle
6. Backing flange
7. Tri-arc cutting blade  
(with transport guard)

8. Locking flange
9. Front flange
10. Securing nut
11. Cutting line cutter
12. String trimmer head
13. Cutting line
14. Trimming guard

## E. Extension attachment

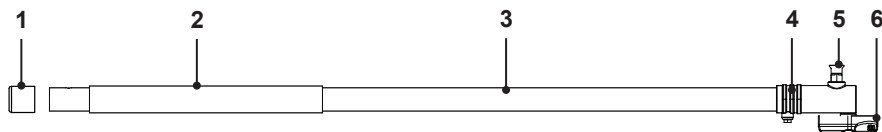

- |                   |                 |
|-------------------|-----------------|
| 1. Protection cap | 4. Shaft clamp  |
| 2. Hand-grip      | 5. Locking knob |
| 3. Shaft tube     | 6. Locking nut  |

## F. Accessories

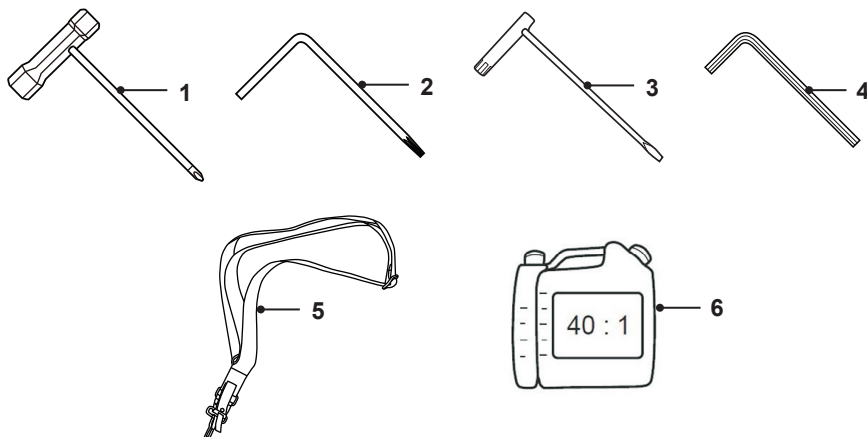

- |  |  |
|--|--|
| 1. Multi-tool I<br>(cross-head screwdriver/socket<br>wrench) | 3. Multi-tool III<br>(flat-head screwdriver/socket wrench) |
| 2. Multi-tool II<br>(torx screwdriver/round rod)             | 4. Hex key 5 mm  |
|  | 5. Harness   |
|  | 6. Fuel mixing bottle                                      |



## Unpacking

1. Unpack all parts and lay them on a flat, stable surface.
2. Remove all packing materials and protective shipping materials, if applicable.
3. Make sure the delivery contents are complete and free of any damage. If you find that parts are missing or show damage do not use the machine and contact your dealer. Using an incomplete or damaged machine represents a hazard to operators and property.
4. Ensure that you have all the accessories and tools needed for assembly and operation. This also includes suitable personal protective equipment.



**WARNING!** The machine and the packaging are not children's toys! Children must not play with plastic bags, sheets and small parts! There is a danger of choking and suffocation!

## You will need

### (items not supplied)

- > Suitable personal protective equipment
- > Sharpening set
- > Fuel funnel with filter
- > Suitable top quality synthetic oil specifically for two-stroke engines, of JASO FC minimum specification.
- > Suitable fuel (octane rating of at least 90, unleaded, maximum 10% renewable ethanol (E10 or below))
- > Container to collect fuel
- > Lubricating gun and lubricant for cutting device
- > First aid kit
- > Dry powder fire extinguisher readily available
- > Soft absorbent cloth (for fuel spills)

### (items supplied)

- > Multi-tool I (F1)
- > Multi-tool II (F2)
- > Multi-tool III (F3)
- > Hex key 5 mm (F4)
- > Fuel mixing bottle (F6)

## Assembly



**WARNING!** The machine must be fully assembled before operation!



Do not use a machine that is only partly assembled or assembled with damaged parts!

Follow the assembly instructions step-by-step and use the pictures provided as a visual guide to assemble the machine easily!

Disconnect the spark plug connector before assembly! Reconnect it after assembly (see "Maintenance").



**NOTE:** Take care of small parts that are removed during assembly or when making adjustments. Keep them secure to avoid loss.



**NOTE:** To prevent the parts from coming loose during the operation, some parts are with reverse threads: turn clockwise to loosen, and turn anti-clockwise to tighten. Read carefully the instructions in this instruction handbook for the correct tightening/loosening direction.

### Assembling the front handle and barrier bar

1. Loosen the 4 pre-assembled bolts on the front handle (A14) using the multi-tool II (F2). Separate the front handle (A14) and the rubber damper from the barrier bar (A15).
2. Attach the rubber damper to the upper drive shaft tube (A13).
3. Clamp the front handle (A14) and the barrier bar (A15) onto rubber damper. Adjust the positions of the parts so that the pin engages into one of the 3 holes (Fig. 1).
4. Secure the front handle (A14) and the barrier bar (A15) with the 4 bolts using the multi-tool II (F2).

1

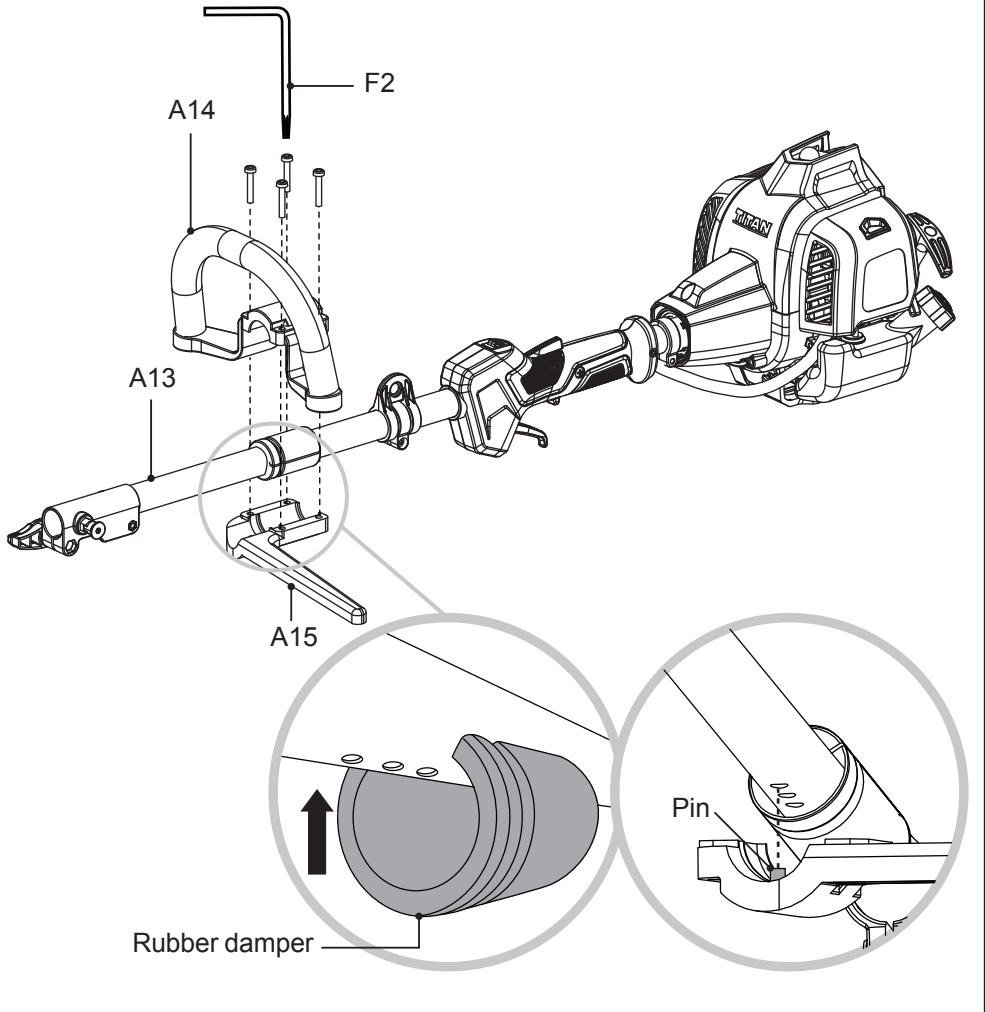

## Assembling the pole pruner attachment



**CAUTION!** Risk of cuts!



The teeth of the saw chain (C7) are very sharp! Protective gloves must be worn for all work on the saw chain (C7).

1. Unscrew the fixing nut (C12) using the multi-tool III (F3) and remove the fixing nut with the spring washer together with the clutch cover (C11) (Fig. 2).

**2**

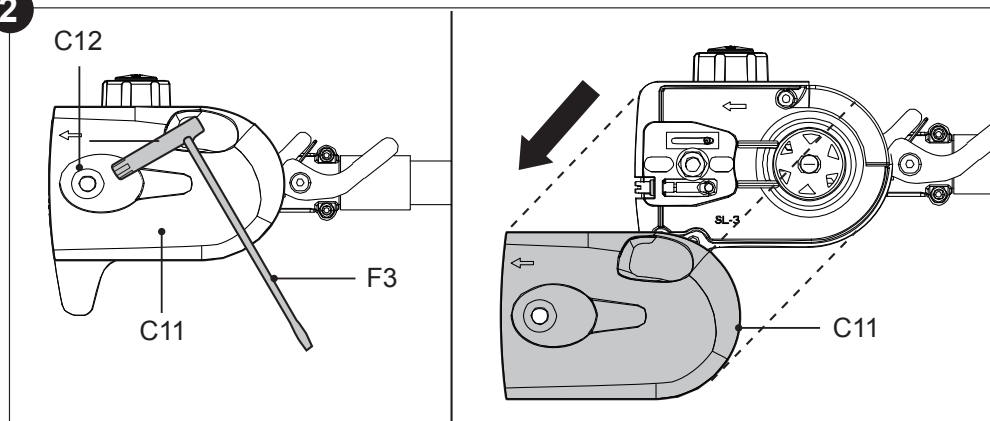

2. Identify the correct saw chain direction. Start to wrap the saw chain (C7) around the guide bar (C6) (Fig. 3).

**3**

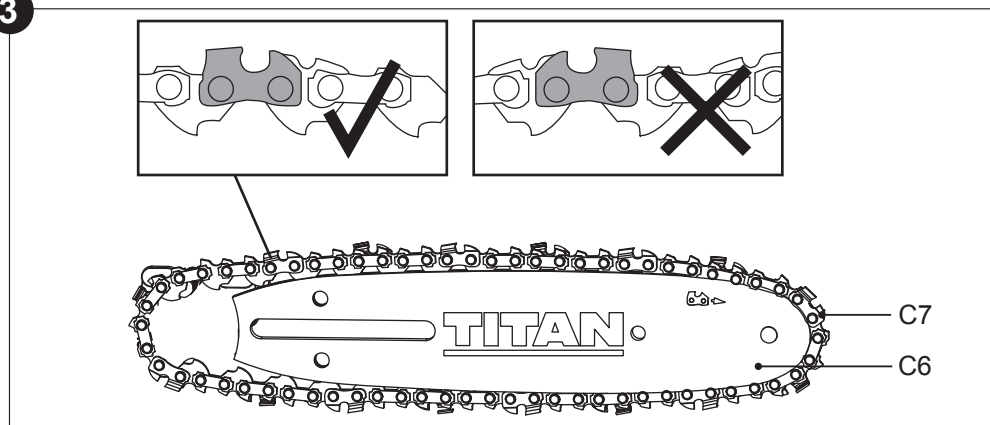

3. Poise the guide bar (C6) near the drive sprocket to fit the rest of the saw chain (C7) around drive sprocket (Fig. 4).

4

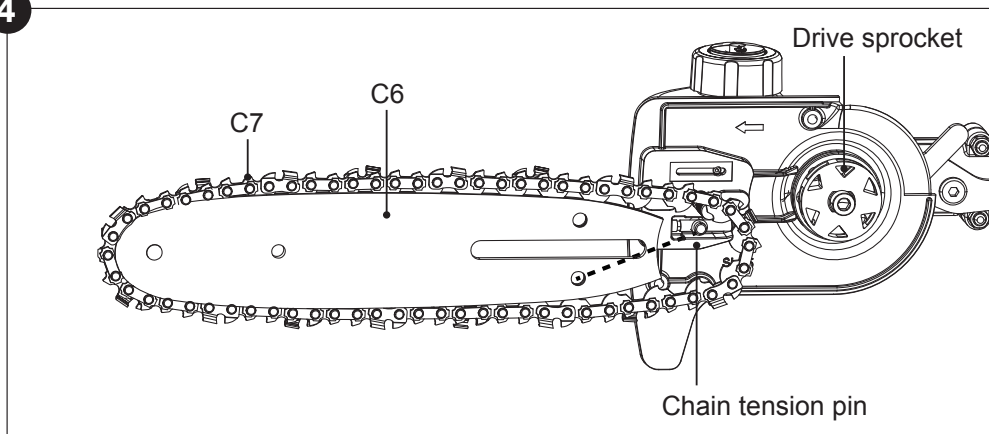

4. With the saw chain (C7) fitted around the drive sprocket and the guide bar (C6), carefully place the guide bar (C6) on the chain tension pin (Fig. 5).

5

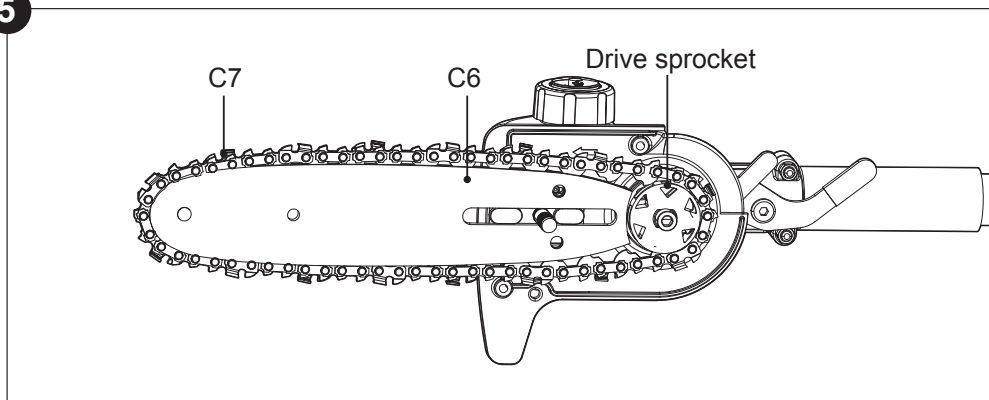

5. Refit the clutch cover (C11) and tighten the fixing nut (C12) with the spring washer using the multi-tool III (F3).



**NOTE:** Always check the saw chain tension before use, after the first cuts and regularly during use, approx. every five cuts. Upon initial operation, new chains can lengthen considerably. This is normal during the break-in period and the interval between future adjustments will lengthen quickly.



**WARNING!** Disconnect the spark plug connector before adjusting saw chain tension!



The cutting edges of the saw chain are sharp! Always wear protective gloves when handling chain!



Always maintain proper chain tension! A loose chain increases the risk of kickback! A loose chain may jump out of the guide bar groove! This may injure the operator and damage the chain! A loose chain will cause rapid wear to the chain, guide bar and the drive sprocket! Tensioning the chain too tightly will overload the engine and cause damage, and insufficient tension can cause chain derailing, whereas a correctly tightened chain provides the best cutting characteristics and prolonged working life! The chain life mainly depends upon sufficient lubrication and correct tensioning!

6. Using the multi-tool III (F3), rotate the tension screw clockwise to increase the tension on the saw chain (C7) or anti-clockwise to decrease the tension on the saw chain (C7) (Fig. 6).

6

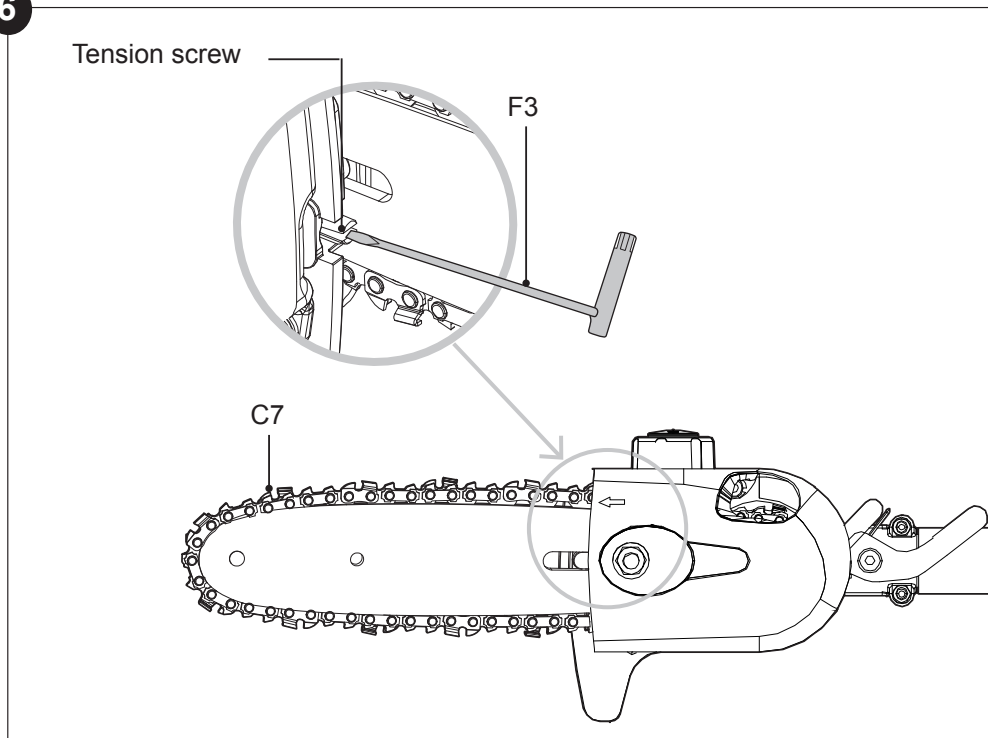

7. Pull the saw chain (C7) along the top of the guide bar (C6) by hand from one end to the other, several times. The chain should feel tight but still move freely. It should be possible to lift up the saw chain (C7) 3-4 mm from the guide bar (C6) (Fig. 7).

7

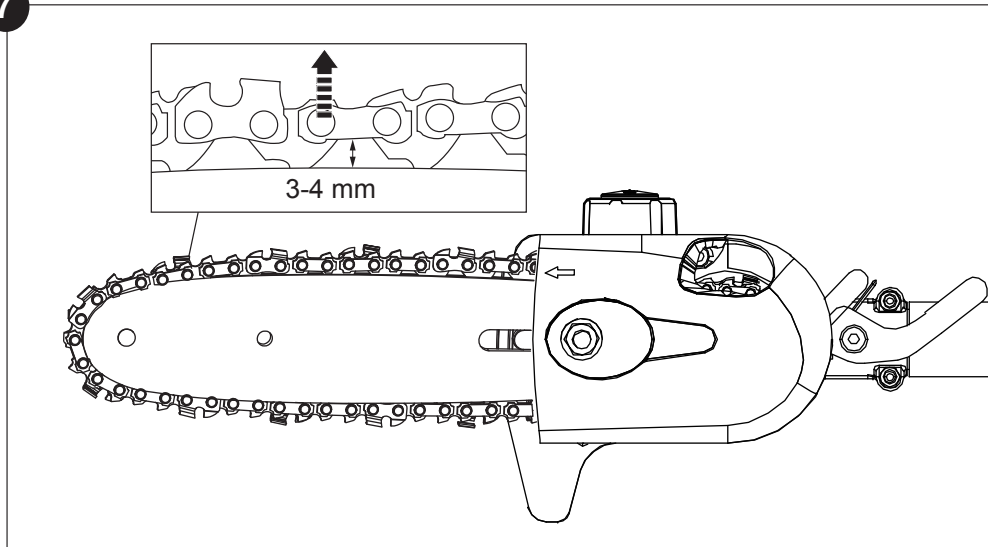

**WARNING!** The machine is not filled with chain oil. It is essential to fill the machine with chain oil before using it! Never operate the machine without chain oil as this will result in extensive damage to the machine! Operating the saw chain dry or with too little chain oil will decrease cutting efficiency, shorten the machine life span and cause rapid wear to the saw chain and guide bar from overheating! Insufficient chain oil is evident by smoke or bar discoloration! Adequate lubrication of the saw chain during cutting operations is essential to minimise friction with the guide bar (C6).

8. Place the machine on a stable, level surface with the oil filler cap (C4) facing upwards. We recommend laying a non-flammable sheet under the attachment.
9. Unscrew the oil filler cap (C4).
10. Fill suitable saw chain oil into the oil tank (C5) using a funnel fitted with a filter to avoid debris entering the tank. Leave approximately 5 mm of space between the top of the saw chain oil and the inside edge of the tank to allow for expansion. Do not overfill.



**NOTE:** Use lubricant oil SAE#10W-30 all year round or SAE#30-#40 in summer and SAE#20 in winter.



**NOTE:** Towards the end of the season, it is advisable to put only as much lubricant in the tank as you need for each cut, so that it is completely used up before you store the machine. Do not let the oil level drop below the MIN marking of the tank.

11. Wipe up spilled saw chain oil with a soft cloth and refit the oil filler cap (C4).



**NOTE:** Always dispose of used saw chain oil and objects contaminated with them in accordance with local regulations.

### Assembling the string trimmer head

The string trimmer head (D12) is used together with both the cutting-attachment guard (D4) and the trimming guard (D14). Use the string trimmer head (D12) for cutting smaller types of weed, lawn grass or similar soft vegetation.

1. Using the hex key (F4) loosen the 2 pre-assembled bolts on the cutting-attachment guard (D4).
2. Attach the cutting-attachment guard (D4) with the trimming guard (D14) onto the plate on the shaft tube (D2). Secure the parts with the 2 bolts using the **hex key (F4)** (Fig. 8).

8

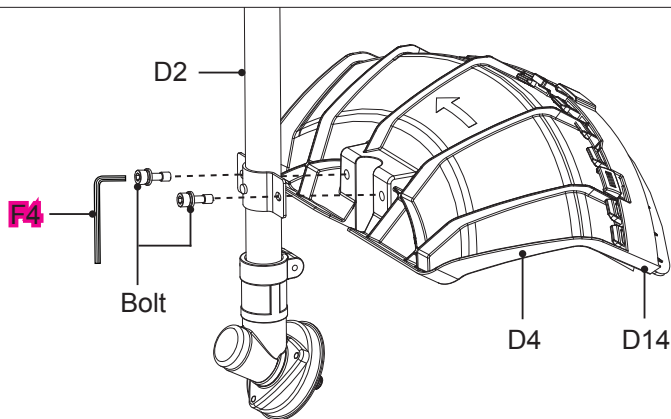



3. Rotate the backing flange (D6) until its hole aligns with the one on the gear head (D3) (Fig. 9).
4. Insert the multi-tool II (F2) into the hole to lock the rotation of the backing flange (D6).
5. Using the multi-tool I (F1) loosen the securing nut (D10) by turning it clockwise.
6. Remove the securing nut (D10), the front flange (D9) and the locking flange (D8) from the gear head (D3).
7. Screw the string trimmer head (D12) onto the spindle (D5) anti-clockwise securely (Fig. 10).
8. Make sure the string trimmer head (D12) is firmly tightened and remove the multi-tool II (F2).

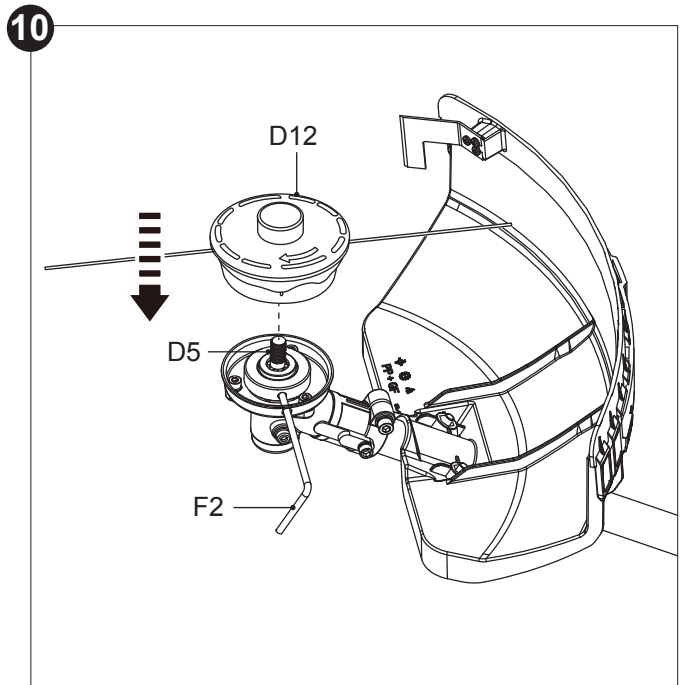
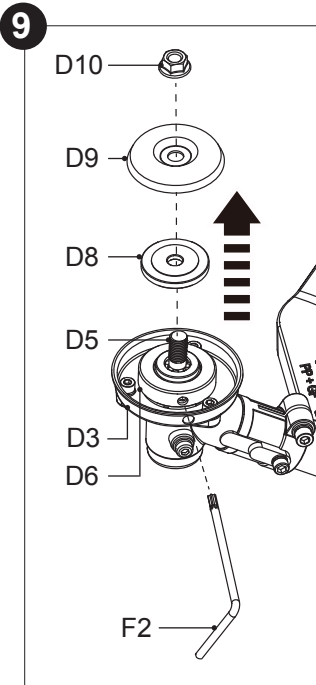

### Assembling the cutting blade

The tri-arc cutting blade (D7) is used together with the cutting-attachment guard (D4) only. Use the tri-arc cutting blade (D7) for cutting heavier weeds, brush and similar vegetation with a thickness of up to **20 mm**.



**CAUTION! Risk of cuts!** Tri-arc cutting blade (D7) is very sharp. Wear protective gloves when handling the tri-arc cutting blade (D7).



1. Press the locking tabs on both sides and pull to detach both ends of the trimming guard (D14) from the cutting-attachment guard (D4) (Fig. 11 and 12).

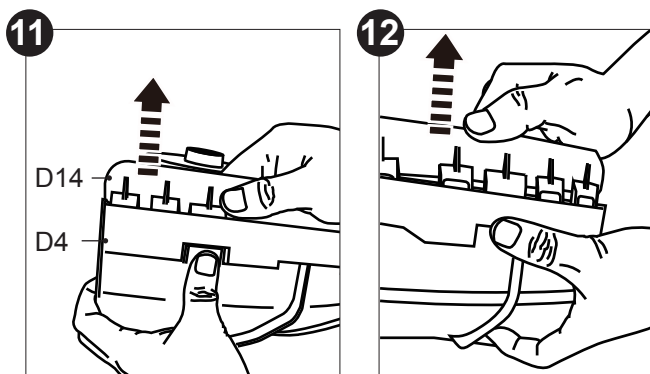

2. **Insert the multi-tool II (F2) under the center buckle to disengage it and remove the multi-tool II (F2) (Fig. 13).**

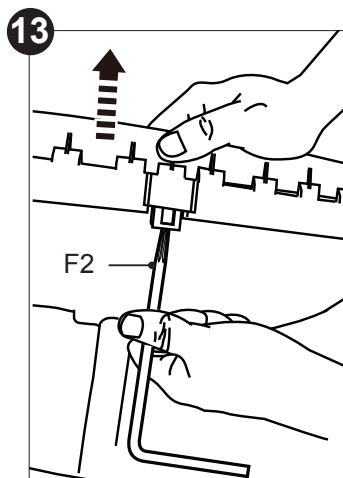

- Remove the trimming guard (D14) completely (Fig. 14).

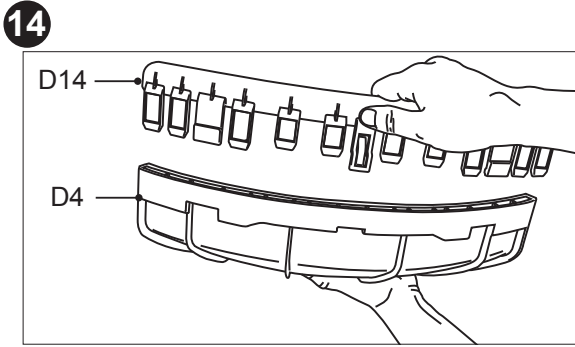

- Using the hex key (F4) loosen the 2 pre-assembled bolts on the cutting-attachment guard (D4).
- Attach the cutting-attachment guard (D4) onto the plate on the shaft tube (D2). Secure the parts with the 2 bolts using the **hex key (F4)** (Fig. 15).

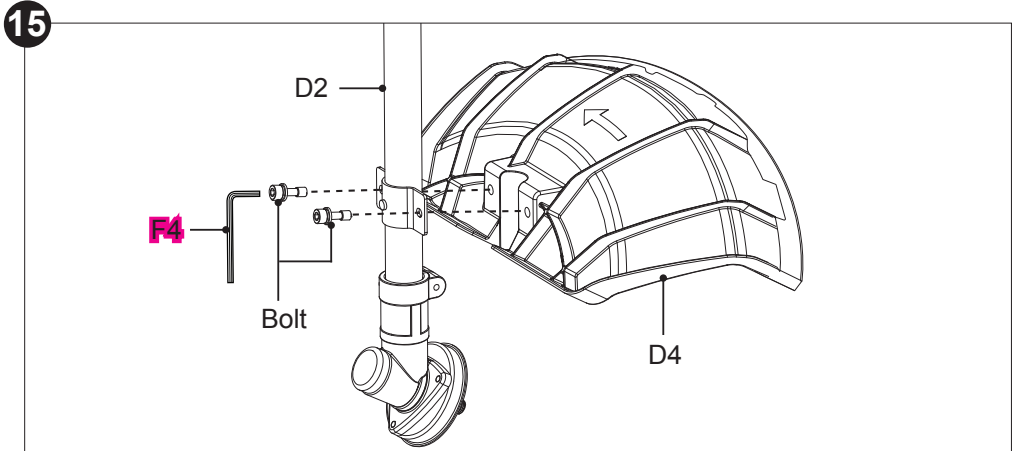

6. Rotate the backing flange (D6) until its hole aligns with the one on the gear head (D3) (Fig. 16).
7. Insert the multi-tool II (F2) into the hole to lock the rotation of the backing flange (D6).
8. Using the multi-tool I (F1) loosen the securing nut (D10) by turning it clockwise.
9. Remove the securing nut (D10), the front flange (D9) and the locking flange (D8) from the gear head (D3).
10. Place the tri-arc cutting blade (D7) onto the spindle (D5). The side with markings should be facing towards the gear head (D3) (Fig. 17).
11. Place the locking flange (D8), front flange (D9) and then the securing nut (D10) onto the spindle (D5). Using the multi-tool I (F1) tighten the securing nut (D10) anti-clockwise to secure the parts in place.
12. Make sure the tri-arc cutting blade (D7) is firmly tightened and remove the multi-tool II (F2).
13. Remove the transport guard from the tri-arc cutting blade (D7) before operation.

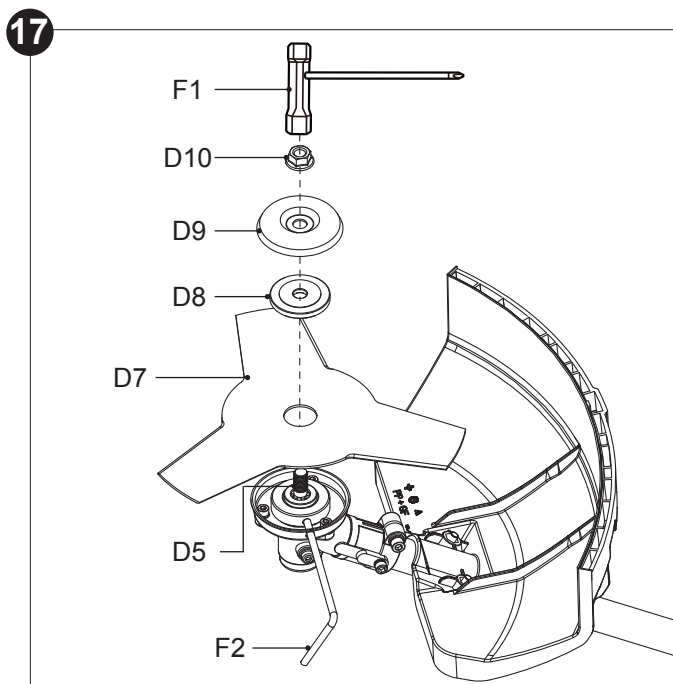
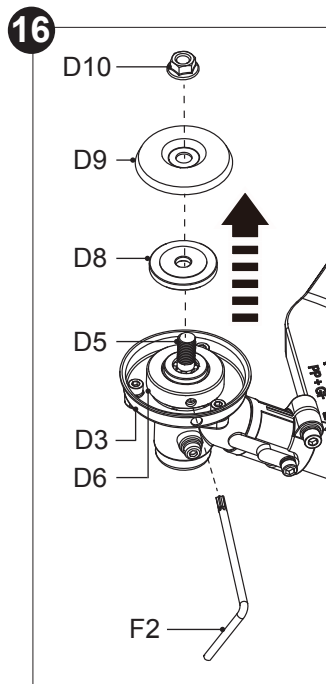

### Assembling the attachment to the drive shaft tube

1. Remove the protective cap (B1/ C1/ D1/ E1) from the attachment to be used.
2. Pull out and rotate the locking knob (A17) on the shaft clamp (A16) anticlockwise to stop at the bracket. Insert the shaft tube (B3/ C3/ D2/ E3) of the attachment into the upper drive shaft tube (A13) (Fig. 18).
3. Release the locking knob (A17) by turning clockwise. Rotate and slide the upper drive shaft tube (A13) inward until the locking knob (A17) snaps into place.
4. Tighten the locking nut (A18) to secure the connection of the tubes.



**NOTE:** The extension shaft can only be used with the pole pruner to allow for longer reach. Tighten the attachments together using the shaft clamp (E4), locking knob (E5) and locking nut (E6) of the extension shaft.

18

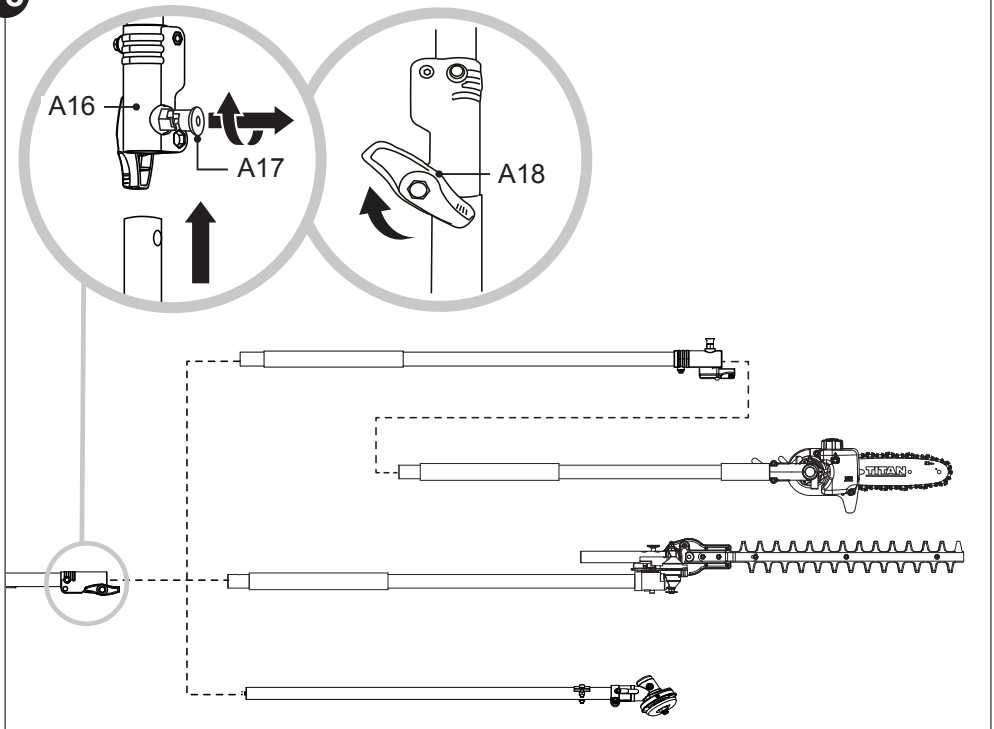

## Filling up fuel and oil



**WARNING!** This machine is not supplied with petrol-oil mixture in the engine! Before operating this machine it is essential to fill it with petrol-oil mixture!

This machine is equipped with a 2-stroke engine. The fuel and oil tank are combined and it is essential to fill a fuel-oil mixture before operating this machine. Observe the technical specifications for suitable fuel and engine oil.





**WARNING!** Fuel and oil are highly inflammable! Fumes will explode if lit! Ensure that there are no naked flames around the machine! Do not smoke while filling fuel and oil!



**NOTE:** To avoid spillage and to filter out debris, use a funnel with filter to fill the fuel mixing bottle (F6) and the fuel tank (A6).

1. Place the machine on a stable, level surface with the fuel tank cap (A5) facing upwards. We recommend laying a non-flammable sheet under the machine.
2. Pour a regular-grade unleaded petrol and a quality engine oil for air cooled 2-stroke engines in the supplied fuel mixing bottle (F6) respectively via the 2 openings. Use the scale markings on different sides for the desired ratio for petrol:oil. For example, fill petrol to scale marking "10" first, and then fill 2-stroke oil to scale marking "10". This indicates a correct ratio of 40:1 when using the scale 40:1.

	$+$		$=$	
100 ml	+	2.5 ml	=	40:1
200 ml	+	5 ml	=	
300 ml	+	7.5 ml	=	
400 ml	+	10 ml	=	

3. Tilt and shake the bottle thoroughly to mix the fuel.



**NOTE:** Use an anti-oxidant added quality oil expressly labelled for air-cooled 2 stroke engine use (**JASO FC GRADE OIL or ISO EGC GRADE**). Do not use **BIA or TWC (2 stroke water-cooling type) mixed oil**. The recommended mixing ratio for petrol:oil is 40:1.



**CAUTION! Risk of machine damage.** Never mix fuel and oil directly in the tank of the machine.

4. Unscrew the fuel tank cap (A5) (Fig. 19).
5. Fill the fuel into the fuel tank (A6). Leave approximately 5 mm of space between the top of the fuel and the inside edge of the tank to allow for expansion. Do not overfill (Fig. 20).
6. Wipe up spilled fuel with a soft absorbent cloth. Refit and screw the fuel tank cap (A5) firmly (Fig. 19).

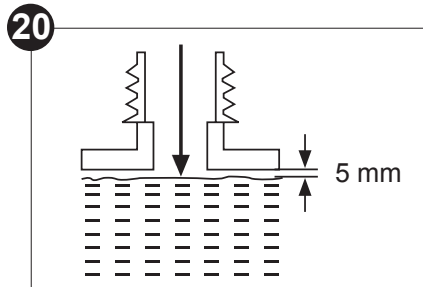
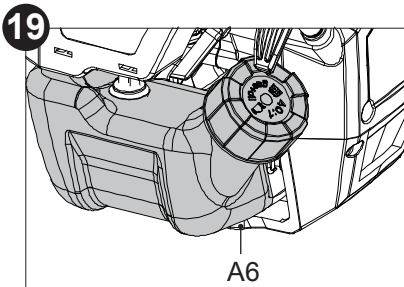

**NOTE:** Fuel and oil deteriorate over time. It may be difficult to start the engine if you use fuel which has been kept for more than 30 days. Towards the end of the season, it is advisable to put only as much fuel in the tank as you need for each use, since it should be completely used up before storing the machine. Empty remaining fuel from the tank after each use.

# Operating controls

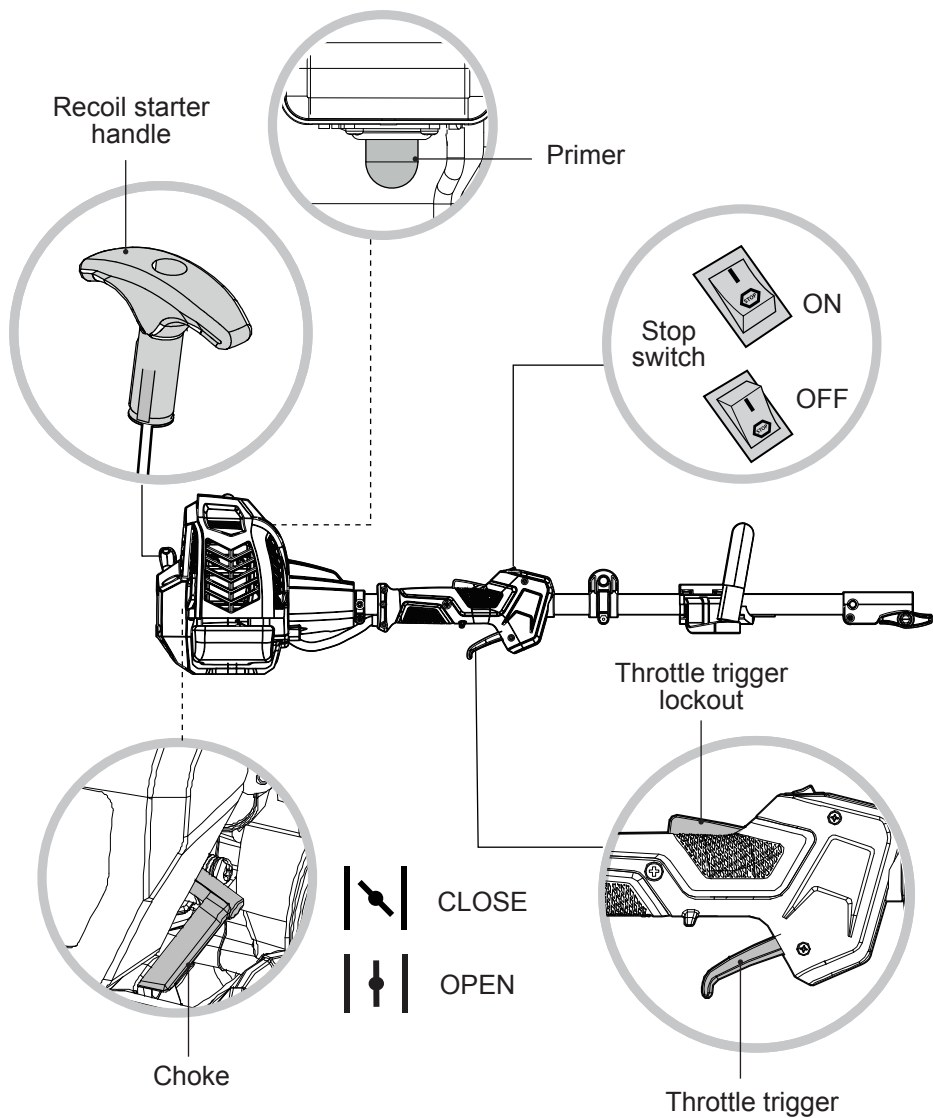



## Preparation



Assemble



Add fuel and oil mixture



For pole pruner only: Add chain oil

## Cold engine

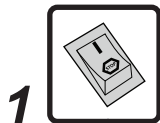

1 Set stop switch to I



2 Set the choke to CLOSE



3 Press primer 6 times



4 Pull recoil starter handle 4 times

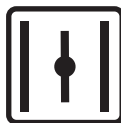

5 Set the choke to OPEN



6 Pull recoil starter handle until engine starts



7 Press the throttle trigger lockout and throttle trigger then release them



8 Run idle for 1 -2 minutes



9 Operate

## Warm engine

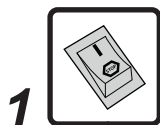

1 Set stop switch to I

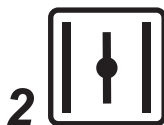

2 Set the choke to OPEN

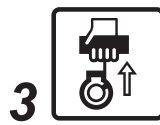

3 Pull recoil starter handle until engine starts



4 Press the throttle trigger lockout and throttle trigger



5 Operate

## Stopping



Release throttle trigger and throttle trigger lockout

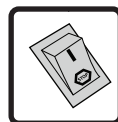

Set stop switch to **STOP**

## Storage



Empty fuel tank



For pole pruner only: empty oil



Clean and maintain



Store



**WARNING!** This quick start provides only a short overview of how to start and stop the machine! For safe use it is essential to read the entire instruction handbook before first use!

## Intended use

This 26 cm<sup>3</sup> 5 in 1 Multi tool TT5MTP26-2 is designated with a maximum power output of 0.75 kW. Depending on the attached accessory this machine is intended to be used as:

- > **Brush cutter:** With the tri-arc cutting blade and cutting-attachment guard attached, the machine is intended to cut heavier weeds, brush and similar vegetation with a thickness of up to **20 mm**.
- > **Grass trimmer:** With the string trimmer head, cutting attachment guard and trimming guard attached, the machine is intended to cut smaller types of weed, lawn grass or similar soft vegetation.
- > **Hedge trimmer:** With the hedge trimmer attachment attached, the machine is intended to trim wide and high hedges, bushes and shrubs.
- > **Pole pruner:** With the pole pruner attachment attached, the machine is intended to cut branches with a thickness of max. 180 mm.



**WARNING!** The machine must be used by an experienced operator\* having read and understood the safety requirements provided within this instruction handbook using appropriate personal protective equipment (PPE)!

This machine must not be used for cutting other materials, such as plastic, stone, metal, wood that contains foreign objects, or materials that are harmful to health. This machine should not be used for cutting unusually thick grass or vegetation, wet grass, or shredding leaves. The brush cutter should not be used to level ground elevations for example molehills.

For safety reasons it is essential to read the entire instruction handbook before first operation and to observe all the instructions therein. This machine is intended for private domestic use only, not for any commercial trade use. It must not be used for any purposes other than those described.

\* A trained operator is a person who has the competence and knowledge in the use and hazards associated with using a machine as well as the precautions to be taken to limit these hazards.

## Safety equipment

The machine has several pieces of safety equipment which reduce the risk of injury when working.

### Cutting-attachment and trimming guard

- > The guards (D4/ D14) protect the operator against thrown objects during operation.
- > Use the grass trimmer only together with the trimming guard (D14) and cutting-attachment guard (D4).
- > Use the brush cutter only together with the cutting-attachment guard (D4).
- > The cutting line cutter (D11) is integrated with the trimming guard (D14) and shortens the cutting line (D13) to the necessary length (Fig. 21).
- > Never use the machine without a guard or with a defective guard.

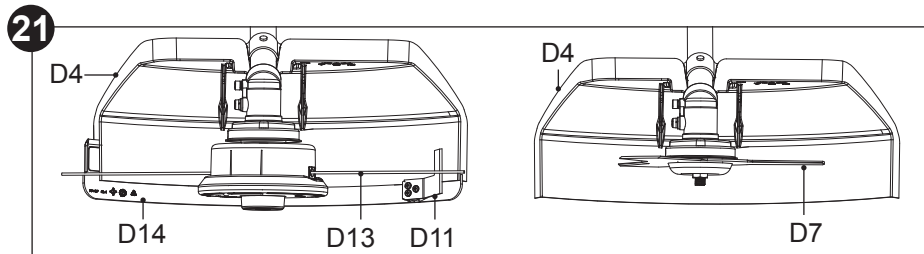

### Harness



**NOTE:** The harness improves working movement and enables the operator to manage the job in a safer way and takes the strain away from the body. Always wear the harness when working with the machine. Always turn the machine off and wait until the attachment tool stops completely before taking off the harness.

1. Place the harness (F5) over your left shoulder crossing the chest and back. The quick-release must be located at the right hip (Fig. 22).
2. Clip the harness (F5) to the harness loop (A12) on the upper drive shaft tube (A13).
3. Adjust the length of the harness (F5) so that the weight of the machine is balanced and the cutting attachment is approximately 10-15 cm above the ground.

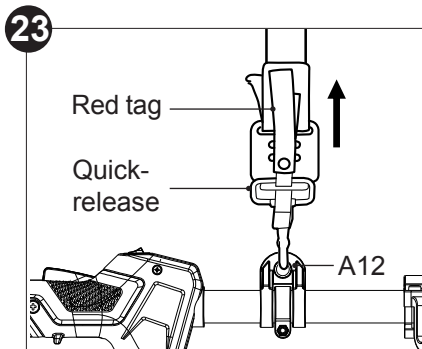
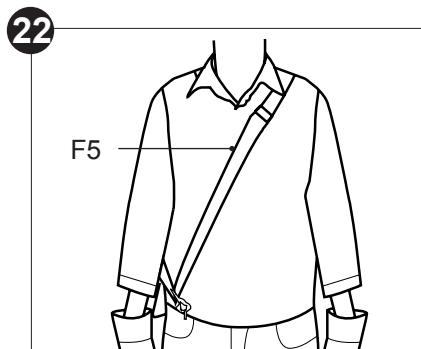

**WARNING!** In the event of an emergency, pull the red tag of the quick-release upwards to release the machine from the harness (Fig. 23).

### Barrier bar

The barrier bar (A15) is intended to maintain a minimum distance at the machine's side from an obstruction or a wall. Always assemble the front handle (A14) with the barrier bar (A15) to the machine (Fig. 24).

### Throttle trigger lockout

The throttle trigger lockout (A10) prevents unintentional start of the throttle trigger (A19). The throttle trigger (A19) can only be activated if the throttle trigger lockout (A10) is depressed (Fig. 25).

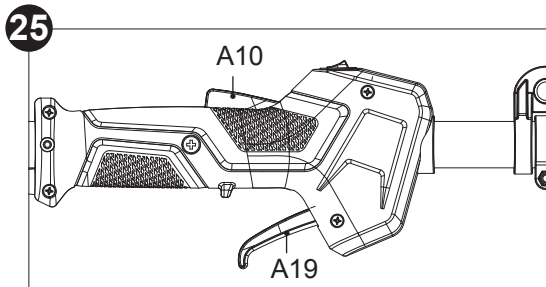
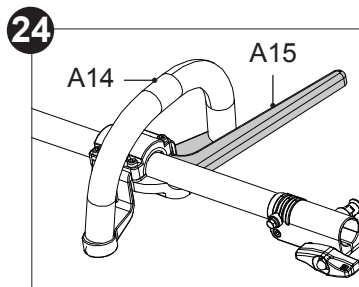

**DANGER! Risk of injury!** The machine must only be put into operation if no faults are found. If any safety equipment is defective, it must be replaced/fixed before the next use.

## Operation

### Check before starting:

1. Check the machine, as well as accessories for damage before each use. Do not use the machine if it is damaged or shows wear.
2. Double check that accessories and the attachment are properly fixed.
3. Check the fuel level, refill if necessary.
4. Always hold the machine by its handles. Keep the handles dry and clean to ensure proper grip.
5. Ensure that the ventilation openings are unobstructed and clear. Clean them if necessary with a soft brush. Blocked ventilation openings may lead to overheating and damage the machine.
6. Wear correct personal protection equipment to protect yourself from hidden objects that may be thrown from the cutting attachments.
7. Ensure the area to be worked is clear of stones, sticks, wires, electrical lines etc. or other objects that could damage the tool.
8. Stop the engine immediately if you are disturbed while working by other people entering the working area. Always let the machine come to complete stop before putting it down.
9. Do not overwork yourself. Take regular breaks to ensure you can concentrate on the work and have full control over the machine.
10. Understand the purpose and use of all safety equipment, including the harness.



**NOTE:** In some countries regulations define at what time of the day and on what special days machines are allowed to be used and what restrictions apply! Ask your community for detailed information and observe the regulations in order to preserve a peaceful neighbourhood and avoid committing administrative offenses!

## Starting the engine



### **DANGER! Risk of fire!**

- > Due to any spilled fuel, the machine can catch fire.
- > Wipe any spilled fuel up before starting using a soft absorbent cloth.
- > Start the engine a few metres away from the place where you have filled it.



### **NOTE: Risk of machine damage!**

Never twist the starter cord around your hand! Only pull on the handle!

Do not suddenly release the recoil starter handle! Allow the rope to return slowly and in a controlled manner each time it is pulled!





**NOTE:** If the engine does not start, the engine may be flooded. Flooding is caused by too much fuel mixture applied at the wrong time and can prevent a machine from starting. Follow below procedure:

1. Remove the spark plug and dry the spark plug.
2. Pull the recoil starter handle slowly for several times to drain the fuel from the combustion chamber.
3. Wait until fuel vapours and refit the spark plug.
4. Clean up any spilled fuel and move the machine at least 3 metres away before starting the engine, to avoid any accidental fire.
5. Wait for the engine to cool down then cold start or warm start the machine as described.

### Starting cold engine

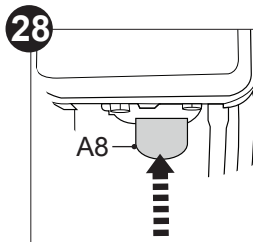
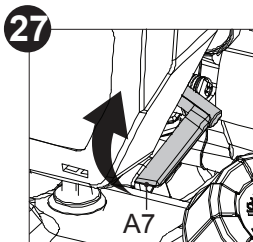
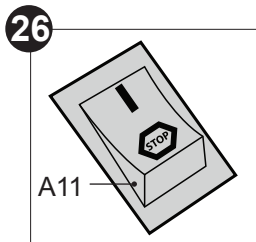
1. Place the machine on a flat and stable surface. The attachment should not touch the ground or any objects.
2. Set the stop switch (A11) to I position (Fig. 26).
3. Set the choke (A7) to CLOSE  position (Fig. 27).
4. Press the primer (A8) 6 times until the bubble is filled with fuel (Fig. 28).



5. Hold the machine securely to the ground with your left hand. Pull the recoil starter handle (A4) slowly with your right hand until you feel a definite resistance and then give it a brisk, strong pull (Fig. 29). Repeat until the engine starts but no more than 4 times.
6. Set the choke (A7) to OPEN  position (Fig. 31).
7. Pull the recoil starter handle (A4) slowly with your right hand until you feel a definite resistance and then give it a brisk, strong pull (Fig. 29). Repeat until the engine starts.
8. Press the throttle trigger lockout (A10) and then slowly press the throttle trigger (A19). After that, release them simultaneously..
9. Let the machine run in idle for 1-2 minutes to let it warm up.

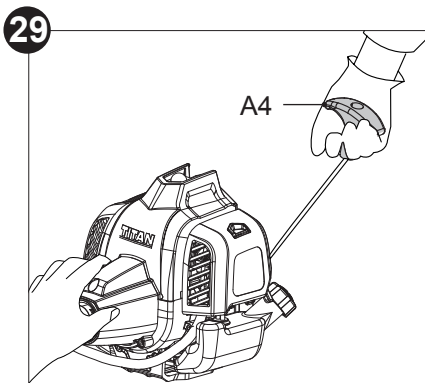

### Starting warm engine

1. Place the machine on a flat and stable surface. The attachment should not touch the ground or any objects.
2. Set stop switch (A11) to **I** position (Fig. 30).
3. Set the choke (A7) to OPEN  $\uparrow\downarrow$  position (Fig. 31).

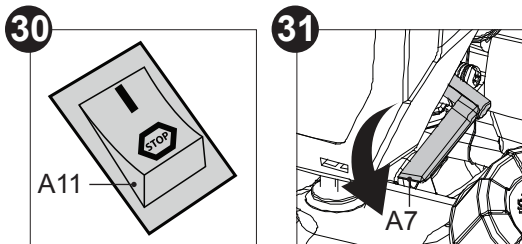

4. Hold the machine securely to the ground with your left hand. Pull the recoil starter handle (A4) slowly with your right hand until you feel a definite resistance and then give it a brisk, strong pull (Fig. 29). Repeat until the engine starts.

### After starting the engine

1. Press the throttle trigger lockout (A10) and then slowly press the throttle trigger (A19) to increase the engine speed.
2. Check if the machine stops rotating when you release the throttle trigger (A19).
3. Once the engine is running smoothly, carefully lift the machine.



**WARNING!** Always carry the machine by using the harness (F5) attached to the machine. Do not carry it only with hands.

### Stopping the engine

1. Release the throttle trigger (A19) and the throttle trigger lockout (A10), and let the machine run in idle for a while.
2. Set stop switch (A11) to **STOP**.



**WARNING!** The machine continues to work for some time even after the engine has been stopped! Wait until the cutting device comes to a complete stop before you put the machine down!



## Brush cutter and grass trimmer use

### Trimmer line feeding

The string trimmer head (D12) is equipped with a bumper to help to feed the cutting line (D13). Tap the bumper on a firm ground while the machine is operating, the spool will release fresh trimming line (Fig. 32). A cutting line cutter (D11) is integrated with the trimming guard (D14) and it cuts the line to a preset length.

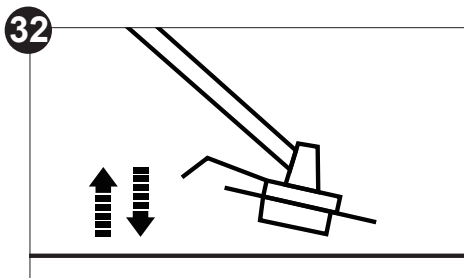

### Cutting/trimming tips



**WARNING!** Avoid contacting the cutting blade with stones, wire, glass, etc. that may cause injury to the operator. Inspect the cutting blade regularly for damage, cracks or breaks.



**WARNING!** When working with the cutting blade, there is always a risk of kickback if the cutting head comes into contact with a hard object. Kickback will cause the sudden stalling of the cutting head, which in turn results in the cutting head being forced in the opposite direction to the rotation of the cutting blade. Ensure that you retain a firm grip with both hands. In an event of a kickback retain a firm stance to avoid injuries.

- > Always hold the machine firmly with both hands on the front handle (A14) and rear handle (A9). Never operate this machine using only one hand.
- > Maintain a firm grip with your thumbs and fingers encircling the handle. A firm grip will help you reduce 'kickback' and maintain control of the machine.
- > Stand upright, do not lean forward and pay attention to the posture. Keep both feet apart to help retain body balance.
- > Carefully plunge the cutting attachment from above when cutting long undergrowth.
- > Move the cutting attachment towards the base of young trees or thicker vegetation.

- > Do not lift the cutting attachment higher than your knee. The higher you hold the cutting attachment, the higher the risk of objects being thrown (Fig. 33).

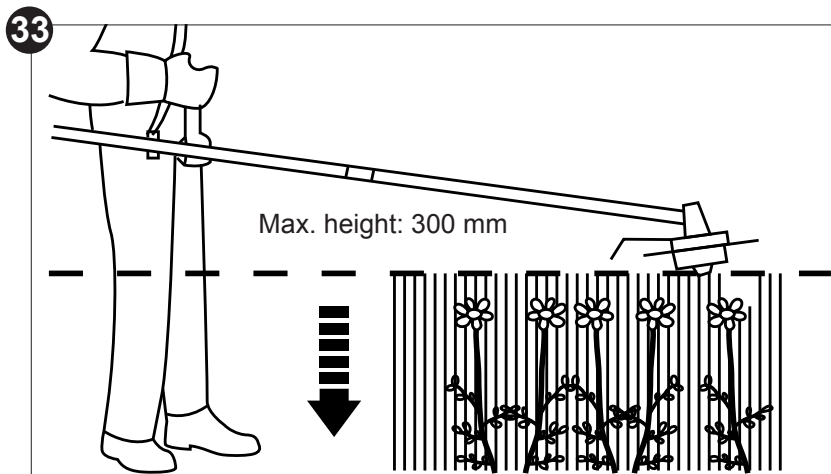

- > Avoid cutting tall grass in one cut. Trim taller grass in stages (Fig. 34).

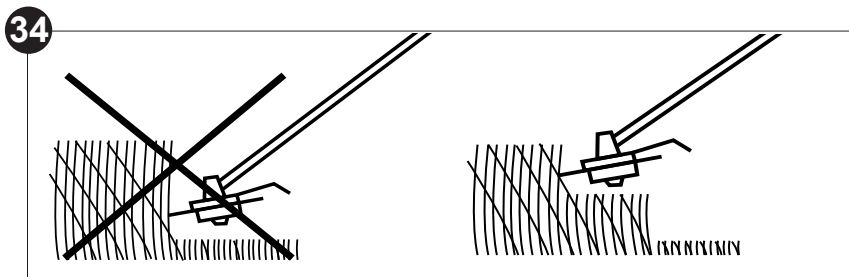

- > Hold the cutting attachment just above the ground at an angle of approximately 30° (Fig. 35).
- > Move the machine with slow and regular motion from left to right before moving it back to the starting position and trimming the next area (Fig. 36).

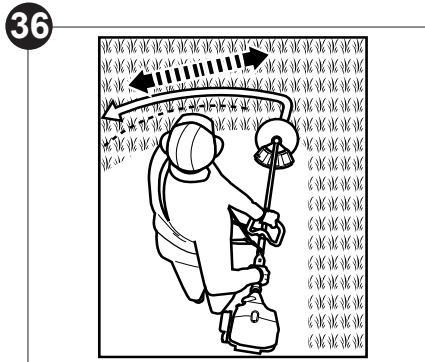
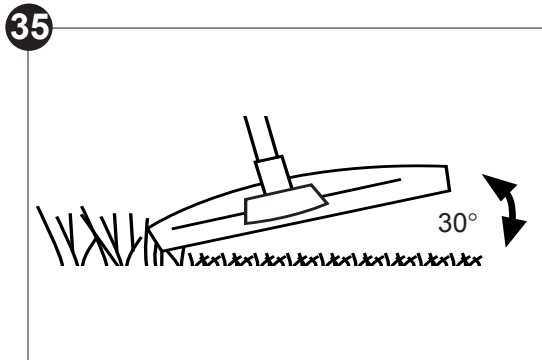

- > Ensure that the cutting attachment remains clean and free of off-cuts to avoid jamming. Make sure the stop switch (A11) is set to **STOP** and the spark plug connector (A3) is removed before checking the cutting attachment for defects.
- > Avoid cutting wet grass as it tends to stick to the moving parts.
- > Pay special attention when performing the work close to trees and bushes (Fig. 37).

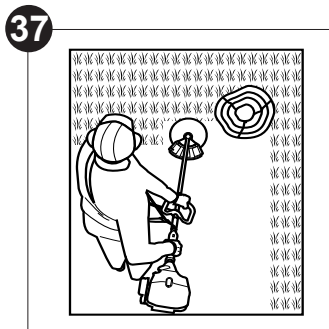

## Pole pruner use

### Angle adjustment

Adjust the attachment angle to suit working conditions.

1. Press the locking lever (C10) down with one hand (Fig. 38).

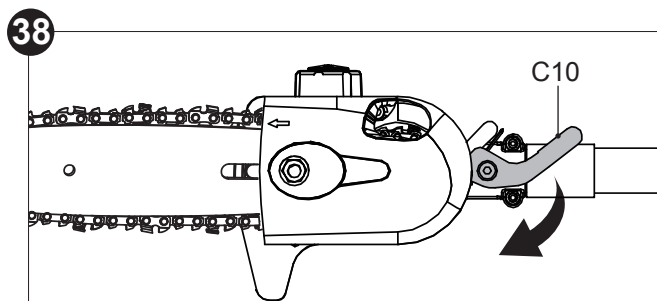

2. Hold the clutch cover (C11) with the other hand and turn until the desired angle is adjusted (Fig. 39). Then angle can be adjusted from  $0^\circ$  to  $+90^\circ$ .

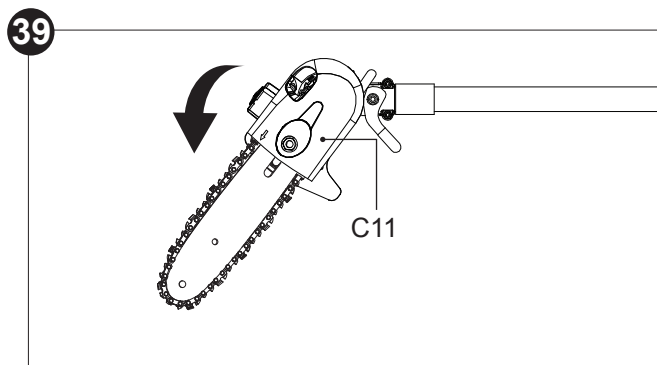

### Kickback



**WARNING!** Beware of kickback! Kickback can lead to dangerous loss of control of the machine and result in serious or fatal injury to the operator or anyone standing close by! Always be alert because rotational kickback and pinch kickback are major machine operational dangers and the leading cause of most accidents!

- > Kickback is the sudden backward/upward motion of the machine, occurring when the chain (at the tip of the chain bar) comes in contact with a log or wood, or when the chain becomes jammed.

- > When kickback occurs the machine reacts unpredictably and can cause severe injuries to the operator or bystanders.
- > With a basic understanding of “kickback”, the element of surprise can be reduced or eliminated. Sudden surprise contributes to the majority of accidents.
- > You should read all the safety warnings and user instructions carefully before attempting to operate this machine.

### To avoid kickback:

- > Never work with a loose, widely stretched or heavily worn chain.
- > Always use a low kickback chain.
- > Ensure correct chain tension.
- > Only use replacement bars and chains specified in this handbook.
- > Follow the sharpening and maintenance instructions for the saw chain. Decreasing the depth gauge height can lead to increased kickback.
- > Never work with the tip of the guide bar.
- > Saw with the guide bar at a flat angle.
- > Always hold the machine firmly with both hands.

### Pruning

- > Always hold the machine firmly with both hands on the front handle (A14) and rear handle (A9). Never operate this machine using only one hand (Fig. 40).
- > Maintain a firm grip with your thumbs and fingers encircling the handles. A firm grip will help you reduce ‘kickback’ and maintain control of the machine.
- > Always hold the machine at an angle of not more than 60° from the horizontal level. Otherwise safe operation is not possible (Fig. 41).

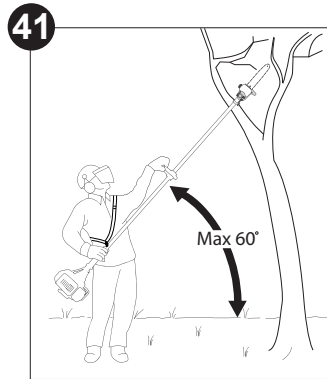
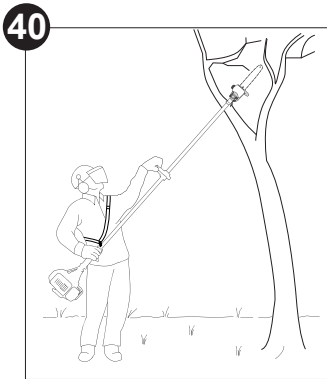

- > Never stand directly under the branches being cut. Objects may fall different than expected. Always position yourself out of the path of falling branches (Fig. 42).
- > Keep other persons away from cutting end of machine and at a safe distance from the work area. Maintain a minimum distance of 15 m to bystanders (Fig. 43).

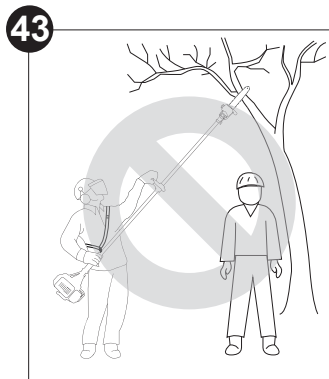
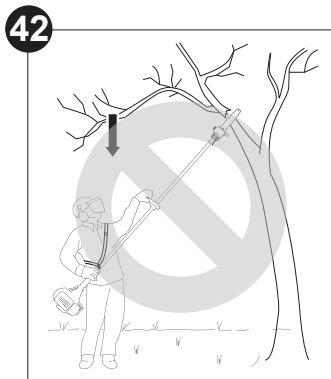

**WARNING!** Never climb into a tree to prune! Do not stand on ladders, platforms, logs, or in any position which may cause you to lose your balance or control of the machine! When pruning trees, it is important not to make the flush cut next to main limb or trunk until you have cut off the limb further out to reduce the weight! This prevents stripping the bark from the main member!

- > Never stand on a ladder or other type of unstable support while using the machine. Insecure stand invites hazards (Fig. 44).



**WARNING!** This machine has not been designed to provide protection from electric shock in the event of contact with overhead electric lines! Therefore do not use machine near cable, electric power or telephone lines. Keep a minimum distance of 15 m to all electric lines (Fig. 45)!

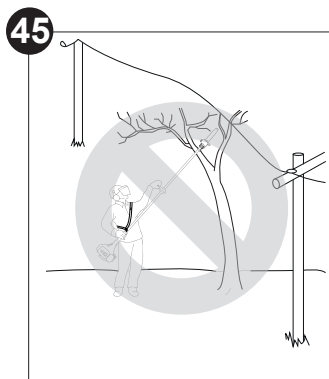
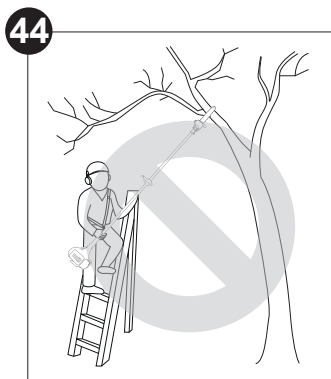

- > Use the machine only with secure footing. Hold the machine at the right-hand side of your body.
- > Do not operate the machine with arms fully extended or attempt to cut areas which are difficult to reach.

- > Keep a firm, steady pressure on the machine while working with it. Do not try to force the machine through the wood, let the cutting device do the work, using the gripping teeth to apply minimal leverage pressure.
- > Beware when reaching the end of the cut. The weight of the machine may change unexpectedly as it cuts free from the wood. Accidents can occur to the legs and feet. Always remove the machine from a wood cut while it is running.



**NOTE:** The chain must be running at full speed before it comes into contact with the wood.

### Cut thin branches

Thin branches can be cut off with one single cut. To prevent the branch from slivering and buckling the branch should be cut off in several pieces (Fig. 46).

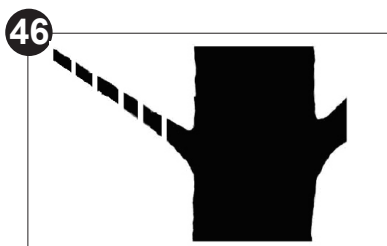

### Cut thick branches

When cutting larger branches, three cuts are necessary as shown below:



**NOTE:** Remove the branches lying on the floor regularly to avoid stumbling hazards. Check the oil level regularly and fill up if necessary. Switch the power off when leaving the machine.

1. First cut into the branch from below, outside of the location where you intend to cut off the branch. The cut should go one third to halfway through the branch (Fig. 47).
2. Cut into the branch from the top, outside from where the branch is to be sawn (Fig. 48).
3. Last, cut off the stump with one clean cut from top to bottom (Fig. 49).

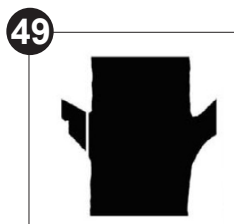
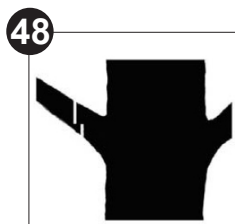
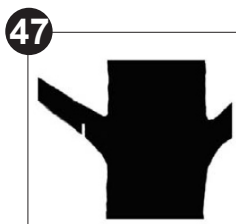

- > You might want to seal the cut with a suitable compound.

## Hedge trimmer

### Angle adjustment

Adjust the attachment angle to suit working conditions.

1. Depress the locking levers (B4) with one hand and hold them in position (Fig. 50).

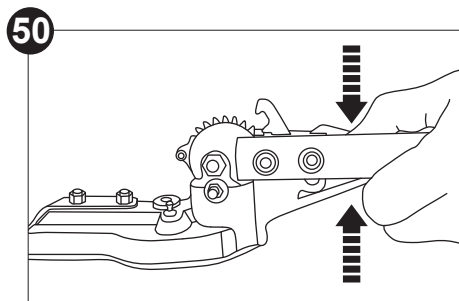

2. Move the shaft tube (B3) with the other hand until the desired angle is adjusted (Fig. 51). Then angle can be adjusted from  $-90^{\circ}$  to  $+60^{\circ}$ .

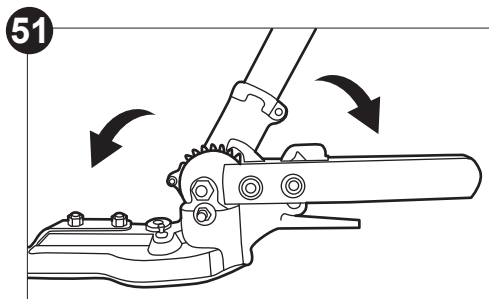

3. Release the locking levers (B4) when the desired angle is adjusted. Ensure that the hook engages between two teeth of the tooth wheel (Fig. 52).

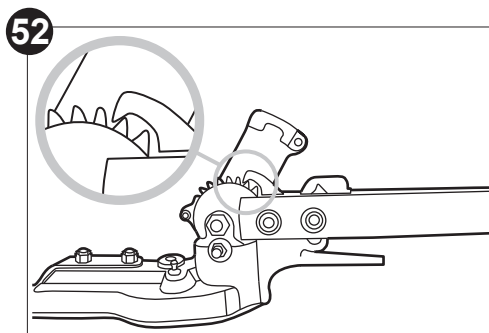



## Trimming

- > Cut and remove branches exceeding the cutting capacity of this machine using a suitable pruner before operation.
- > Always hold the machine firmly with both hands on the rear handle (A9) and hand grip (B2). Never operate this machine using only one hand.
- > Cut both sides from the bottom cutting upwards to the top. This will prevent any of the cuttings falling into the path of the area still to be cut (Fig. 53).

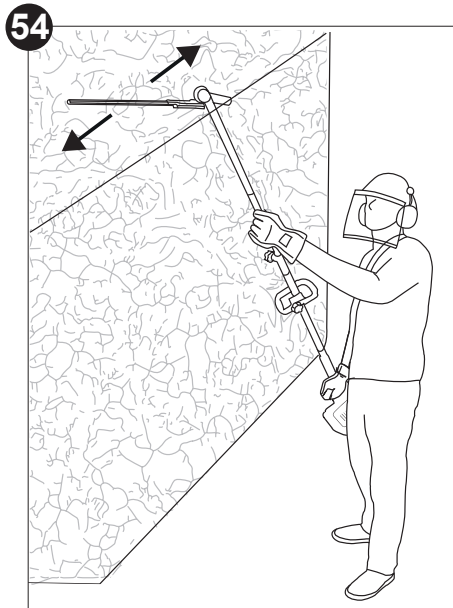
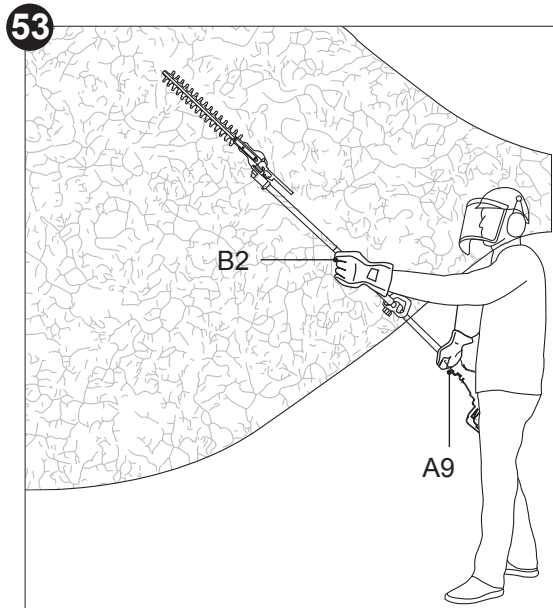

- > After cutting the sides proceed to the top.
- > When cutting wide hedges with the cutting area in sight move the cutter blade lightly through the cutting surface in a sweeping motion following the shape of the hedge or shrub. A slight tilt downwards of the cutter blade in the direction of motion is recommended for optimum cutting performance (Fig. 54).
- > Move the machine with slow motion forward when cutting higher hedge and the cutting area out of sight.
- > Do not to rush and do not attempt to cut too much with one stroke of the cutter blade.
- > Cut in a number of stages if the area being cut is particularly long to achieve a better result; smaller cuttings will allow for easy composting.



**NOTE:** When shaping it is advisable to achieve a trapezoidal shape (Fig. 55). A trapezoidal cut corresponds to the natural growth of plants and results in optimal hedge growth, as it will expose more light to the bottom of the hedge.

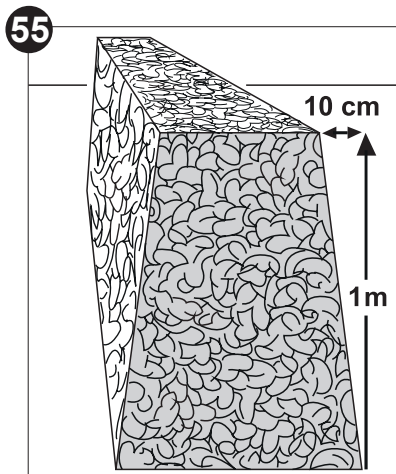

## After use of the machine

1. Set the stop switch (A11) to **STOP**, disconnect the spark plug connector (A3) and let the engine cool down.
2. Check, clean and store the machine as described in section “**The golden rules for care**”.



**WARNING!** The cutting device continues to rotate for some time after the engine has been stopped. Wait until the cutting device comes to a complete stop before setting the machine on the ground.

## The golden rules for care

 **WARNING!** Always stop the engine, disconnect the spark plug connector (A3) and let the engine cool down before performing inspection, maintenance and cleaning work.

 **DANGER!** Proper maintenance is essential for safe and trouble free operation. Improper maintenance, or failure to address a problem instantly can cause a malfunction which can result in serious injury or even death.

1. Keep the machine clean. Remove debris after each use and before storage.
2. Regular and proper cleaning helps to ensure safe operation and prolongs the life of the machine.
3. Inspect the machine before each use for worn and damaged parts. Do not operate it if you find broken and worn parts. Replace worn parts as necessary or contact an authorised service centre for repair before using the machine again.

 **WARNING!** Only perform repairs and maintenance work according to these instructions! All other works must be performed by a qualified person!

## Cleaning and Maintenance

 **NOTE:** Do not use chemical, alkaline, abrasive or other aggressive detergents or disinfectants to clean this machine as they might be harmful to its surfaces.

### Cleaning the housing

- > Use a damp, lint-free cloth to clean the housing.
- > Do not immerse the machine into water or any liquids.
- > Clean the ventilation openings located on the back and right-hand side of the engine with a soft brush. Clogged ventilation openings might cause the engine to overheat.
- > Wipe the surface with a dry cloth afterwards.

### Cleaning the attachments

- > Disassemble the attachment in reverse order from assembly.
- > Use compressed air (max. 3 bar) to remove dirt accumulated on the attachment.
- > Use a damp, lint-free cloth to clean the surface.
- > Wipe the surface with a dry cloth afterwards.

### Cleaning the cutting device (hedge trimmer)

- > Keep the cutting device (B6) clean and free of debris. Remove trimmings.
- > Keep the cutter blade (B7) sharp to retain a good cutting performance. Replace a worn or damaged cutting device (B6) with a new one of the same type.
- > Lubricate the cutting device (B6) after each use to prolong the life span of the machine. Apply light machine oil along the edge of the cutter blade (B7) (Fig. 56).
- > Check it for any damage and protect it from corrosion. If necessary take the cutter blades to an authorized dealer for sharpening.
- > Tighten loose nuts on the cutting device (B6) with a proper wrench to ensure safe operation (Fig. 57).

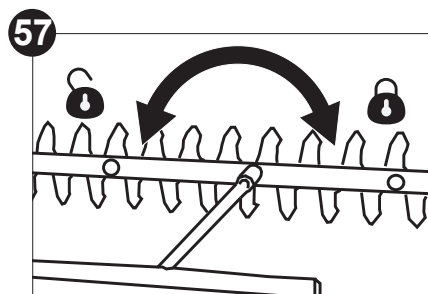
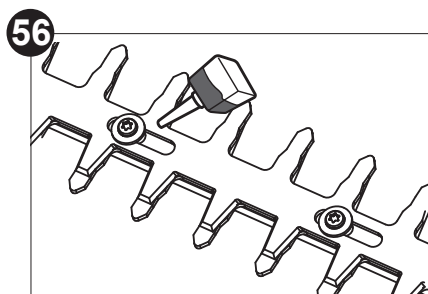

### Guide bar (pole pruner)

Most guide bar (C6) problems can be prevented merely by keeping the machine well maintained. Incorrect filling and non-standard cutter and depth gauge settings are the causes of most guide bar problems, primarily resulting in uneven bar wear. As the bar wears unevenly, the rails widen, which may cause the chain to clatter and make it difficult to complete straight cuts. If the guide bar is insufficiently lubricated and the machine is operated with a saw chain which is too tight, this will contribute to rapid bar wear. To help minimise bar wear, maintenance of the guide bar as well as the saw chain is recommended.

- > Disassemble the guide bar (C6) and saw chain (C7) in reversed order from assembly.
- > Check the oil dispenser for clogging and clean if necessary to ensure proper lubrication of the guide bar and saw chain during operation. Use a soft wire small enough to insert into the oil dispenser (Fig. 58).

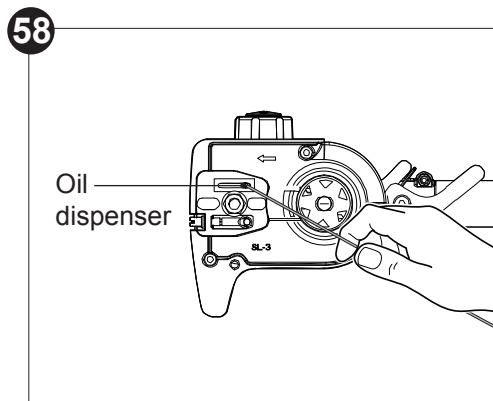



**NOTE:** The condition of the oil passages can be easily checked. If the passages are clear, the chain will automatically give off a spray of oil within seconds of the machine starting. This machine is equipped with an automatic oiling system.

- > Clear residue from the rails on the guide bar (C6) using a screwdriver, putty knife, wire brush or other similar tool. This will keep the oil passages open to provide proper lubrication to the guide bar (C6) and saw chain (C7) (Fig. 59).
- > Check the guide bar "rail" for wear: Hold a ruler (straight edge) against the side of the guide bar and "cutter side plates". If there is a gap between the ruler and guide bar the guide bar "rail" is normal. If there is no gap (ruler flush against the side of the guide bar) the guide bar 'rail' is worn and needs to be replaced with a new one of the same type (Fig. 60).

59

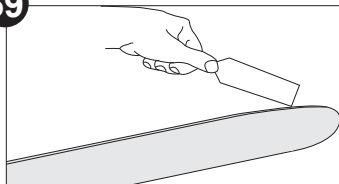

60

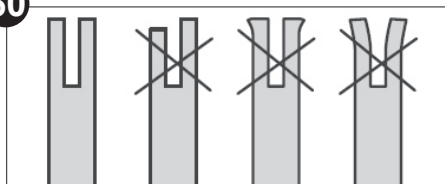

- > Turn the guide bar (C6) 180° to allow even wear, thereby extending the life span of the guide bar (C6).
- > Check the saw chain (C7) for possible wear and damages. Replace it with a new one if required. Experienced operator can sharpen a dull saw chain (see section "**Saw chain sharpening**").
- > Refit the saw chain (C7) and the guide bar (C6) as described under "**Assembly**" chapter in "**Before you start**" section.

## Saw chain sharpening



**WARNING!** Only sharpen the saw chain yourself if you are trained and have experience! Use proper tools to sharpen the saw chain!



**NOTE:** Never saw with a blunt chain. The saw chain is blunt if you have to force the machine to do the job and the chips are very small.

- > Have the saw chain (C7) sharpened professionally at an authorised service centre or sharpen the chain yourself by using a suitable sharpening kit. Also observe the sharpening instructions supplied with the sharpening kit.
- > The height difference between the tooth and the ridge is the cutting depth. When sharpening the saw chain (C7) you have to consider the following points (Fig. 61)
  - File angle
  - Cutting angle
  - File position
  - Diameter of round file
  - File depth

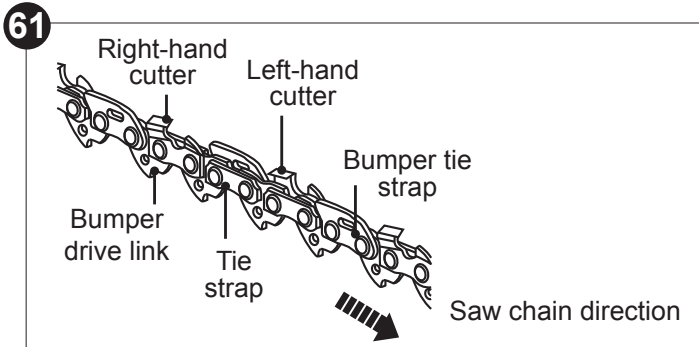

- > To sharpen the chain proceed as follows:
  - Use protective gloves.
  - Ensure the chain is correctly tensioned.
  - Lock the chain on the bar.
- > Use a suitable file with a diameter 1.1 times the cutting tooth depth. Make sure 20% of the file diameter is above the cutter's top plate.
- > A file guide is available from most reputable tool merchants and is the easiest way to hold the file at the correct position.

- > File at an angle perpendicular to the bar, and at an angle of  $30^\circ$  to the direction of travel (Fig. 62).

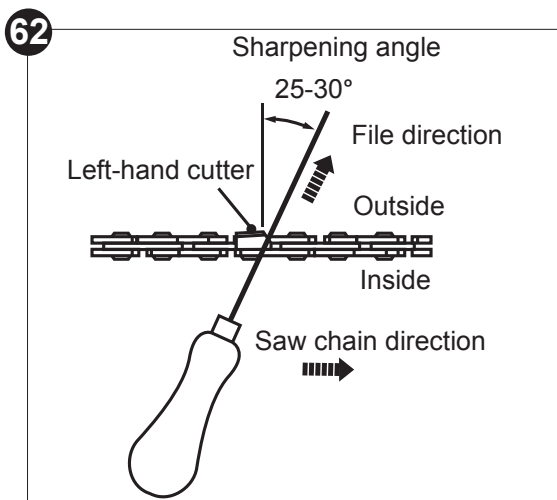

- > File each tooth from the inside towards outside only. File one side of the chain first than turn the saw around and repeat the process.
- > Sharpen each tooth equally by using the same number of strokes.
- > Keep all cutter lengths equal. Check the safety depth gauge height every 5 sharpenings. If the depth gauges are also trimmed it is essential that the original profile be restored.
- > Use a depth gauge measuring instrument to check the height of the depth gauge. Depth gauge measuring jigs are available from most reputable tool merchants (Fig. 63).

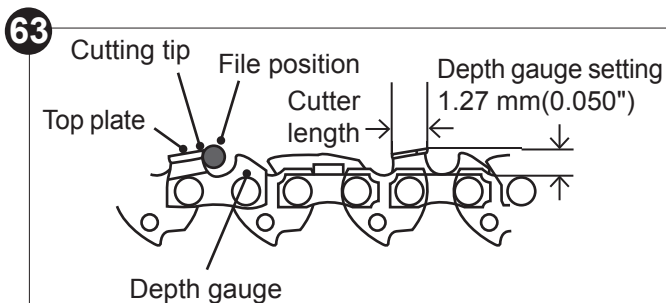

### Sprocket wheel

1. Clean the sprocket wheel.
2. Using a disposable lube gun, insert the needle nose into the lubrication hole (C8) and inject grease until it appears at the outside edge of the sprocket (Fig. 64).
3. Rotate the saw chain (C7) by hand. Repeat the lubrication procedure until the entire sprocket has been greased.

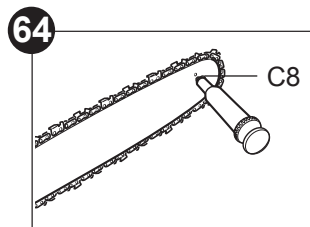

### Brush cutting blade sharpening

- > Remove the brush cutting blade (D7) attachment from the gear head (D3).
- > Clean off the entire blade with a wire brush and soapy water.
- > Dry the blade off with a rag.
- > Rub the blade with lubricating oil using a clean rag.
- > Angle a flat file against the side of the blade and stroke in an angled up and down motion. Do this on both sides of all cutting edges.
- > Check that all sides are evenly sharpened.



**NOTE:** If in doubt, have the cutting blade (D7) sharpened professionally at an authorised service centre.

## Cutting line

If the cutting line (D13) is used up, either the spool must be replaced by one of the same type or the cutting line must be refilled.

Before replacing the spool or the cutting line:

1. Lay the machine on a flat stable surface with its spool assembly facing upwards.
2. Remove the trimmer head (D12) from the gear head (D3).
3. Press the tabs on the side of the spool assembly and pull to detach the spool (Fig. 65).

To replace the spool:

1. Remove the old one from the spool assembly.
2. Replace with a new one of the same type.

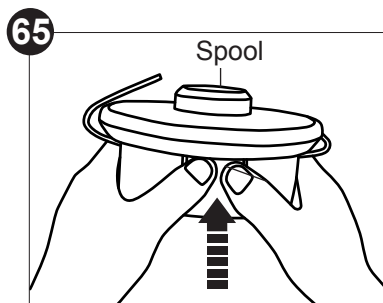



To replace the cutting line:

1. Take out the old spool and remove the remaining cutting line.
2. Cut a new 4 meter long cutting line with a diameter of 2.4 mm.
3. Form a loop at the middle of the line and insert this loop into the hook on the spool (Fig. 66).
4. Wind the two parts of the cutting line clockwise firmly around the spool (Fig. 67).
5. Place the spool into the spool assembly and pass each end of the cutting line through the respective holes.
6. Pull both ends of the cutting line so there is 15 cm of loose cutting lines.

66

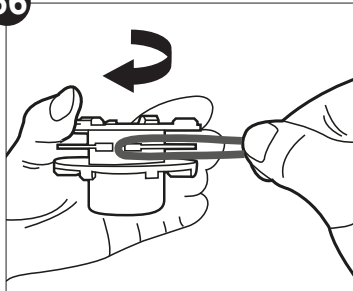

67

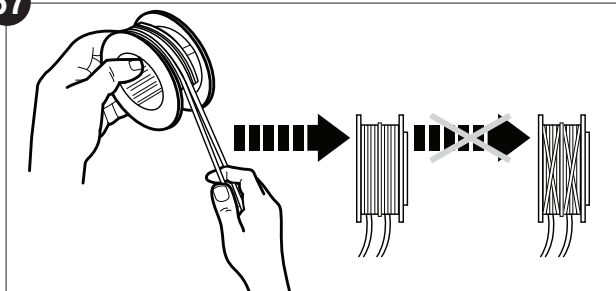

**WARNING!** After changing the cutting line, run the machine under no load for at least a minute to make sure that the line was installed properly and the machine operates correctly.



**WARNING!** Never use steel threads or cutting lines!



**NOTE:** To keep the cutting line elastic, remove the trimmer head (D12) and store it in a damp place. Two or three days before the start of the new season, place the cutting line in water to keep it flexible.

## Air filter

Inspect the air filter regularly. Clean or replace it with a new one if necessary.

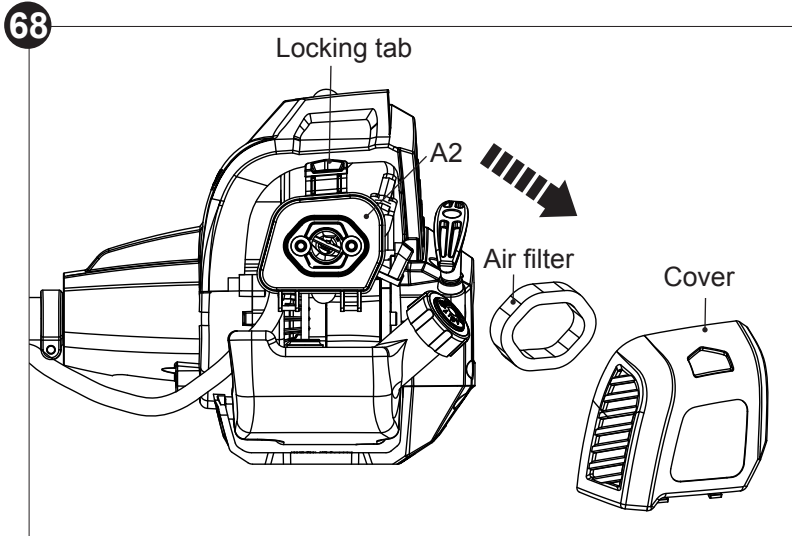

1. Press the locking tab on the air filter case (A2) and remove its cover (Fig. 68).
2. Remove the air filter and tap it on a stable surface to remove dust. Use compressed air (max. 3 bar) to remove stubborn dust.
3. Refit the air filter and the cover of the air filter case (A2).

### Fuel, fuel lines and fuel filter

The fuel tank of this machine is fitted with a filter located at the free end of the fuel pipe. If it is necessary to clean or replace the fuel filter, contact an authorised service centre or a similarly qualified person.

- > Keep fuel fresh (less than 30 days) or add fuel stabiliser.
- > Empty the fuel tank after every use.
- > Run the machine dry of fuel in idle before storage.
- > Replace fuel lines and fuel filters every 2 years.

## Spark plug



**NOTE:** For good performance, the spark plug must be properly gapped and must be free of deposits.

Inspect the spark plug every 25 hours of operation or before long-term storage over 30 days. Clean or replace with a new one if necessary.

1. Unplug the spark plug connector (A3).
2. Loosen the spark plug anti-clockwise using the multi-tool I (F1) and remove it carefully.
3. Check the spark plug for damage and wear. The colour of the ground electrode should be light-brown.
4. Remove the deposits from the electrode with a soft wired brush. Avoid heavy cleaning of the electrode.
5. Dry the spark plug with a soft cloth, if it is wet from fuel.
6. Check the spark plug gap. It should be **0.6-0.7 mm** (Fig. 69).
7. Replace with a new spark plug if either the electrode or the insulation is damaged.
8. When replacing the spark plug, first screw it in hand tight and then lightly tighten it with the multi-tool I (F1).

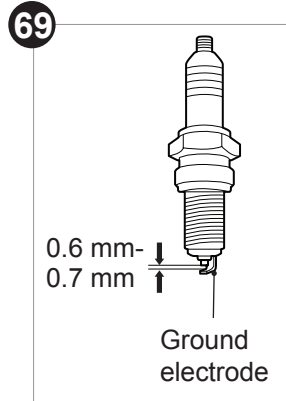

**NOTE:** Do not over tighten the spark plug to avoid any damage!

9. Refit the spark plug connector (A3).

## Gear box and bevel gear

The bevel gear is pre-oiled by the manufacturer. If it is necessary to lubricate the gear box, contact an authorised service centre or a similarly qualified person.

## Muffler

If it is necessary to adjust or replace the muffler, contact an authorised service centre or a similarly qualified person. Inspect the fixing screws or bolts of the muffler. Tighten them if they are loosening.

### Carburetor

The carburetor has been carefully set at the factory. Adjustment may be necessary if you notice that the engine will not idle (i.e the cutting attachment keeps moving when the throttle is released). Contact an authorised service centre or dealer to do idle speed adjustment.



**WARNING!** Keep others away when making idle speed adjustment. Keep cutting attachment off the ground and out of contact with any object. The cutting attachment will be running during this procedure. Wear protective equipment and observe all safety precautions.

1. Release throttle and allow engine to idle.

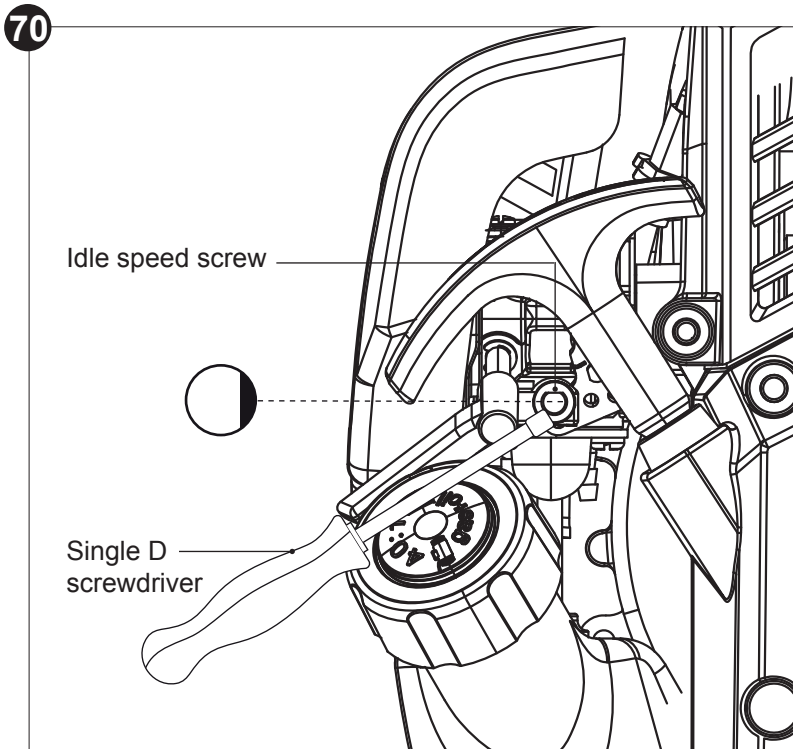

2. Use a single D screwdriver (not provided) to turn the idle speed screw clockwise to increase engine speed if engine stalls or dies (Fig. 70).
3. Use a single D screwdriver (not provided) to turn idle speed screw counter-clockwise to decrease engine speed if the cutting attachment moves (Fig. 70).

## Maintenance table

Inspect and maintain this machine regularly based on below maintenance table. Keep the machine in good working condition during maintenance.

Part	Task	Before/after each use	Every 10 hours of operation	Every 25 hours of operation
Spark plug	check			X
	clean			X
	replace		whenever necessary	
Air filter	check	X		
	clean		X	
	replace		whenever necessary	
Fuel filter and fuel lines	clean		whenever necessary	
	replace		whenever necessary, or every 2 years	
Cutting device	check	X		
	lubricate	X		
	clean	X		
	replace/sharpen		whenever necessary	
Gear box (hedge trimmer)	lubricate			X
Sprocket wheel (pole pruner)	lubricate			X
Saw chain	check	X		
	lubricate	X		
	clean	X		
	replace		whenever necessary	
Guide bar	check	X		
	clean	X		
	replace		whenever necessary	

## Spare parts/Replacement parts



**WARNING! Risk of injury!** Use of non-genuine replacement components can result in serious personal injury or death.

The following parts of this machine may be replaced by the consumer. Spare parts are available at an authorised dealer or through our customer service.

Description	Model no. or Specification
Brush cutting blade	3 tooth, Ø 255 x Ø 25.4 mm
Cutting line	Ø 2.4 mm nylon line
Guide bar	M1500833-1041TL
Saw chain	CL15033X
Spark plug	CHAMPION RCJ6Y <b>(Gap of electrodes: 0.6-0.7 mm) or other model with same specifications</b>

## Repair

This machine does not contain any parts that can be repaired by the consumer. Contact an authorised service centre or a similarly qualified person to have it checked and repaired.

## Storage



**WARNING! Risk of injury!** Make sure that unauthorized persons do not have access to the machine!



**NOTE:** Good storage conditions are important for keeping the machine trouble-free.

1. Clean the machine as described above.
2. Attach transportation guards, if applicable.
3. Store the machine and its accessories in a dry, frost-free, well-ventilated place.
4. Always store the machine in a place that is inaccessible to children. The ideal storage temperature is between 10 and 30 °C.
5. Store the machine in its bag or cover it with a suitable cloth to protect it against dust.

### Short term storage (less than 1 day)

1. Let the machine cool down before storage.
2. Store the machine as horizontally as possible. Make sure that no fuel-oil mixture can run out of the carburetor.

### Long term storage



#### NOTE: Risk of machine damage!

- > If you are not going to use the machine for a while, remove the fuel from the machine.
- > Store the machine in a dry place and far away from possible sources of ignition such as ovens, gas thermostats, etc.

1. Empty the fuel tank (A6) using a fuel pump if you are not going to use the machine for more than 1 day, and especially before winter storage.
2. Start the engine and let it run in idle mode until the engine stops by itself (see "Starting the engine").
3. Let the engine cool down (approx. 5 min).
4. Unplug the spark plug connector (A3).
5. Remove the spark plug using the multi-tool I (F1).
6. Let a teaspoon of clean two-stroke engine oil run into the combustion chamber.
7. Pull the recoil starter handle (A4) slowly several times in order to coat the internal components with the engine oil.
8. Refit the spark plug.

## Transportation

1. Stop the engine and disconnect the spark plug connector (A3) before transporting the machine.
2. Attach transportation guards, if applicable.
3. Always carry the machine by its upper drive shaft tube (A13) (Fig. 71).

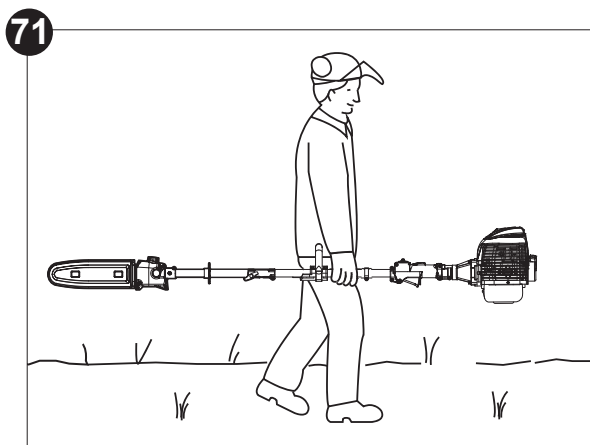

4. Protect the machine from any heavy impact or strong vibrations which may occur during transportation in vehicles.
5. Secure the machine to prevent it from slipping or falling over, loss of fuel, damage and injury.

### **If you are transporting the machine in a vehicle:**

- > Let the machine cool down.
- > Empty the fuel tank (A6).
- > Secure the machine against slipping using bungee cords (not provided) and vehicle's transportation hooks.



## Troubleshooting

Suspected malfunctions are often due to causes that the operators can fix themselves. Therefore check the machine using this section. In most cases, the problem can be solved quickly.



**WARNING!** Only perform the steps described in these instructions! All further inspection, maintenance and repair work must be performed by an authorised service centre or a similarly qualified person if you cannot solve the problem yourself!

### Engine

Problem	Possible cause	Solution
Engine does not start	Fuel tank empty?	Fill the fuel tank.
	Stop switch set to <b>STOP</b> ?	Set the stop switch to I. Follow the engine starting procedure.
	Incorrect starting procedure?	Follow the engine starting procedure.
	Spark plug connector not firmly attached?	Attach the spark plug connector firmly.
	Spark plug is wet?	Dry the spark plug.
	Spark plug connector is dirty?	Clean the spark plug connector.
	Excess fuel in the combustion chamber?	Release throttle trigger lockout, set the choke to <b>OPEN</b> position and pull the recoil starter handle several times. If the engine does not start: remove spark plug and dry the electrodes.
	Spark plug is soiled (tip is rusted)?	Clean or replace the spark plug.
	Primer has not been pressed at cold start?	Press the primer 6 times and restart. Follow the engine starting procedure.
	Gap between electrodes is too large?	Set the gap between electrodes to <b>0.6-0.7 mm</b> .
Incorrect fuel or incorrect mixture?	Stop the engine, empty tank, then fill up with the correct mixture of fuel to oil (40:1).	

Engine does not reach the maximum speed.	Air filter is soiled?	Clean the air filter.
	Incorrect fuel or incorrect mixture?	Stop the engine, empty tank, then fill up with the correct mixture of fuel to oil (40:1).
	Carburetor setting not correct?	Have a qualified person adjust the carburetor.
Bad cutting performance.	Inappropriate cutting attachment used?	Select the proper cutting attachment for the use.
	Wrong cutting height?	Adjust the cutting height.
	Cutting/trimming guard clogged?	Clean the cutting/trimming guard.
	Cutting blade is not sharp enough?	Sharpen or replace the cutting blade.
Excessive vibration/noise or smoke.	Cutting attachment broken?	Replace the broken attachment.
	Flanges/nut loosened?	Stop the engine and re-tighten the loosened fasteners.
	Incorrect fuel or incorrect mixture?	Stop the engine, empty tank, then fill up with the correct mixture of fuel to oil (40:1).

### Brush cutter/grass trimmer

Problem	Possible cause	Solution
Bad cutting performance.	Inappropriate cutting attachment used?	Select the proper cutting attachment for the use.
	Wrong cutting height?	Adjust the cutting height.
	Cutting/trimming guard clogged?	Clean the cutting/trimming guard.
	Cutting blade is not sharp enough?	Sharpen or replace the cutting blade.
Excessive vibration/noise or smoke.	Cutting attachment broken?	Replace the broken attachment.
	Flanges/nut loosened?	Stop the engine and re-tighten the loosened fasteners.
	Incorrect fuel or incorrect mixture?	Stop the engine, empty tank, then fill up with the correct mixture of fuel to oil (40:1).

**Pole pruner**

<b>Problem</b>	<b>Possible cause</b>	<b>Solution</b>
Bad cutting performance.	Saw chain not tensioned properly.	Tension the saw chain properly.
	Saw chain is dull/damaged.	Sharpen or replace the saw chain.
Excessive vibration/ noise or smoke.	Saw chain is dull/damaged.	Sharpen or replace the saw chain.
	Screws/nuts are loosened.	Stop the engine and re-tighten the loosened screws/nuts.

**Hedge trimmer**

<b>Problem</b>	<b>Possible cause</b>	<b>Solution</b>
Bad cutting performance.	Cutter blades are worn?	Have a qualified person sharpen or replace the cutter blades.
	Thickness of the branches exceeds capacity.	Only cut branches with a diameter of maximum 24 mm.
Excessive vibration/ noise or smoke.	Cutter blades damaged?	Replace the broken attachment.
	Nuts on the cutter blades loosened?	Stop the engine and re-tighten the loosened nuts.
	Incorrect fuel or incorrect mixture?	Stop the engine, empty tank, then fill up with the correct mixture of fuel to oil (40:1).

## Recycling and disposal

1. Old machines are potentially recyclable and do not, therefore, belong in your household rubbish. You are requested to assist us and our contribution to saving resources and protecting the environment by handing in this machine to an equipped collection centre (if there is one available).
2. Petrol, oil, used oil, a mixture of oil and petrol and objects soiled with oil e.g. cleaning cloths do not belong in the household rubbish. Dispose of oil-contaminated items in accordance with the local guidelines and hand them in at recycling centres.
3. The machine comes in a package that protects it against damage during shipping. Keep the package until you are sure that all parts have been delivered and the machine is operating properly. Recycle the package afterwards.

## Guarantee

We take special care to select high quality materials and use manufacturing techniques that allow us to create products incorporating design and durability. This product has a manufacturer's guarantee of 2 years against manufacturing defects, from the date of purchase (if bought in store) or date of delivery (if bought online), at no additional cost for normal (non-professional or commercial) household use.

To make a claim under this guarantee, you must present your proof of purchase (such as a sales receipt, purchase invoice or other evidence admissible under applicable law), please keep your proof of purchase in a safe place. For this guarantee to apply, the product you purchased must be new, it will not apply to second hand or display products. Unless stated otherwise by applicable law, any replacement product issued under this guarantee will only be guaranteed until expiry of the original period guarantee period. This guarantee covers product failures and malfunctions provided the product was used for the purpose for which it is intended and subject to installation, cleaning, care and maintenance in accordance with the information contained in these terms and conditions, in the user manual and standard practice, provided that standard practice does not conflict with the user manual.

This guarantee does not cover defects and damage caused by normal wear and tear or damage that could be the result of improper use, faulty installation or assembly, neglect, accident, misuse, or modification of the product. Unless stated otherwise by applicable law, this guarantee will not cover, in any case, ancillary costs (shipping, movement, costs of uninstalling and reinstalling, labour etc), or direct and indirect damage.

Rights under this guarantee are enforceable in the country in which you purchased this product. Guarantee related queries should be addressed to the store you purchased this product from.

The guarantee is in addition to and does not affect your statutory rights.





This guarantee does not affect your statutory rights.

## Customer care and technical helpline

### A better way to repair your tools

Kingfisher takes special care in creating high-quality garden power tools that are designed to last. But if a fault develops with your garden power tool and you need to claim under the guarantee, the Customer Care and Technical Helpline can support with technical assistance or if required, arrange a free courier collection from your home, assess your garden power tool for fault, repair it, and return it.

Deciding to repair your product rather than buying a replacement and adding to the mountain of waste is a more sustainable choice and you will be doing your bit for the environment.

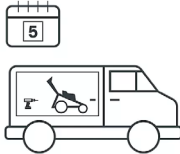
How does it work?				
				
<b>Step 1</b>	<b>Step 2</b>	<b>Step 3</b>	<b>Step 4</b>	<b>Step 5</b>
Find your proof of purchase and get in touch with the Customer Care and Technical Helpline.	Chat to them about the problem with your tool.	They will provide technical and user advice or alternatively arrange a courier collection from your home*.	The team will access and test and if necessary, repair your product back to full working order.	Your repaired tool will be returned to you via courier within 5 to 7 working days.



\* **NOTE:** Before collection, all fuel must be removed from petrol powered machines.

### Get in touch

If you need help or more information, please contact the Customer Care and Technical Helpline:

UK: 0800 0789647

EIRE: 1800 932226

Opening hours are Monday – Friday, 8am-5pm

---

## Availability of spare parts

---

Contact the customer service helpline for assistance or visit [www.kingfisherspares.com](http://www.kingfisherspares.com)

For assistance contact the customer services helpline:

UK: 0800 0789647 [uk@kingfisherservice.com](mailto:uk@kingfisherservice.com)

EIRE: 1800 932226 [eire@kingfisherservice.com](mailto:eire@kingfisherservice.com)

Further information about this product can also be found at:

[www.kingfisher.com/products](http://www.kingfisher.com/products)



## (UK) DECLARATION OF CONFORMITY

## Product

- > 26 cm<sup>3</sup> 5 in 1 Multi Tool
- > TT5MTP26-2
- > 000001 - 999999

## Name and address of the manufacturer or his authorised representative:

Kingfisher International Products Limited  
3 Sheldon Square  
London W2 6PX  
United Kingdom

This declaration of conformity is issued under the sole responsibility of the manufacturer.

## Object of the declaration

**Product**26 cm<sup>3</sup> 5 in 1 Multi Tool**Model**

TT5MTP26-2

**EAN**

5059340256061

The object of the declaration described above is in conformity with the relevant legislation:

Supply of Machinery (Safety) Regulations 2008 as amended  
Noise Emission in the Environment by Equipment for Use Outdoors Regulations 2001 as amended  
Electromagnetic Compatibility Regulations 2016 as amended  
The Restriction of the use of Certain Hazardous Substances in Electrical and Electronic Equipment Regulations 2012 as amended

Measured Sound Power Level: 108.4 dB(A)

Guaranteed Sound Power Level: 110 dB(A)

Engine Model: SL34G

References to the relevant designated standards used or references to the other technical specifications in relation to which conformity is declared:

EN ISO 11680-1:2021  
EN ISO 10517:2019  
EN ISO 11806-1:2011  
EN ISO 14982:2009

Authorised signatory and technical file holder:  
Kingfisher International Products Limited  
3 Sheldon Square  
London W2 6PX  
United Kingdom

David Awe  
Group Quality & Sustainability Director  
On: 04/05/2022



(EN) EU DECLARATION OF CONFORMITY  
 (FR) DÉCLARATION UE DE CONFORMITÉ  
 (PL) DEKLARACJA ZGODNOŚCI UE  
 (RO) DECLARAȚIA DE CONFORMITATE UE  
 (ES) DECLARACIÓN UE DE CONFORMIDAD  
 (PT) DECLARAÇÃO DE CONFORMIDADE UE

Product/ Produit/ Produkt/Produsul/Producto/Produto		
<ul style="list-style-type: none"> <li>&gt; Petrol multi tool 5 in 1/Outil multifonction 5-en-1/Spalinowe narzędzie wielofunkcyjne 5w1/Instrument multi benzină 5 în 1 / Herramienta multifunción 5 en 1/Multiferramenta 5 em 1</li> <li>&gt; TT5MTP26-2</li> <li>&gt; 26 cm<sup>3</sup>, 0.75 kW</li> <li>&gt; 000001 - 999999</li> </ul>		
Name and address of the manufacturer or his authorised representative: Nom et adresse du fabricant ou de son mandataire: Nazwa i adres producenta lub jego upoważnionego przedstawiciela: Denumirea și adresa producătorului sau a reprezentantului său autorizat: Nombre y dirección del fabricante o de su representante autorizado: Nome e endereço do fabricante ou do respetivo mandatário:		
Kingfisher International Products B.V., Rapenburgerstraat 175E, 1011 VM Amsterdam, The Netherlands		
This declaration of conformity is issued under the sole responsibility of the manufacturer. La présente déclaration de conformité est établie sous la seule responsabilité du fabricant. Niniejsza deklaracja zgodności wydana zostaje na wyłączną odpowiedzialność producenta. Prezenta declarație de conformitate este emisă pe răspunderea exclusivă a producătorului. La presente declaración de conformidad se expide bajo la exclusiva responsabilidad del fabricante. A presente declaração de conformidade é emitida sob a exclusiva responsabilidade do fabricante.		
Object of the declaration/Objet de la declaration/Przedmiot deklaracji/Obiectul declarației/Objeto de la declaración/Objeto da declaração		
<b>Product/Produit/Produkt/Produsul/Producto/Produto</b>	<b>Model/Modèle/Model/Modelul/Modelo/Modelo</b>	<b>EAN</b>
Petrol multi tool 5 in 1/Outil multifonction 5-en-1/Spalinowe narzędzie wielofunkcyjne 5w1/Instrument multi benzină 5 în 1 / Herramienta multifunción 5 en 1/Multiferramenta 5 em 1	TT5MTP26-2	5059340256061
The object of the declaration described above is in conformity with the relevant Union harmonisation legislation: L'objet de la déclaration décrit ci-dessus est conforme à la législation d'harmonisation de l'Union applicable: Wymieniony powyżej przedmiot niniejszej deklaracji jest zgodny z odnośnymi wymaganiami unijnego prawodawstwa harmonizacyjnego: Obiectul declarației descris mai sus este în conformitate cu legislația relevantă de armonizare a Uniunii: El objeto de la declaración descrita anteriormente es conforme con la legislación de armonización pertinente de la Unión: O objeto da declaração acima descrito está em conformidade com a legislação de harmonização da União aplicável:		



2006/42/EC as amended	Machinery Directive
2014/30/EU as amended	Directive Electromagnetic compatibility
2000/14/EC as amended	Outdoor Noise Directive
2016/1628/EU Regulation	Gaseous and Particulate Pollutant Emission Limits
2011/65/EU as amended	Directive Restriction of the use of certain hazardous substances in electrical and electronic equipment
Directive 2006/42/CE relative aux machines	
2014/30 / UE telle que modifiée	Directive Compatibilité électromagnétique
Directive 2000/14/CE relative aux émissions sonores extérieures	
Règlement (UE) 2016/1628 relatif aux exigences concernant les limites d'émission pour les gaz polluants et les particules polluantes	
Directive 2011/65/UE relative à la limitation de l'utilisation de certaines substances dangereuses dans les équipements électriques et électroniques	
2006/42/WE w zmienionej dyrektywie maszynowej	
2014/30 / UE ze zmianami	Dyrektywa Kompatybilność elektromagnetyczna
2000/14/WE w zmienionej dyrektywie w sprawie hałasu na zewnątrz	
2016/1628/UE limity emisji zanieczyszczeń gazowych i cząstek stałych	
2011/65 / UE ze zmianami	Dyrektywa Ograniczenie stosowania niektórych niebezpiecznych substancji w sprzęcie elektrycznym i elektronicznym
2006/42/CE, astfel a fost modificată	Directiva privind echipamentele
2014/30/UE, astfel a fost modificată	Directiva privind compatibilitatea electromagnetică
2000/14/CE, astfel a fost modificată	Directiva privind zgomotul în aer liber
2016/1628/UE Regulamentul privind emisiile de poluanți gazoși și de particule poluante	
2011/65/UE, astfel a fost modificată	Directiva privind limitarea utilizării anumitor substanțe periculoase în echipamentele electrice și electronice
Directiva sobre maquinaria modificada	2006/42/CE
2014/30/UE modificada	Directiva Compatibilidad electromagnética
2000/14/CE modificada	Directiva sobre ruido al aire libre
2016/1628/Reglamento de la UE	Límites de emisiones de contaminantes gaseosos y partículas
2011/65/UE modificada	Directiva Restricción del uso de determinadas sustancias peligrosas en equipos eléctricos y electrónicos
2006/42/CE como diretiva de máquinas alteradas	
2014/30/UE como alteração da compatibilidade eletromagnética	
2000/14/CE como diretiva de ruído exterior alterada	
Limites de emissão de poluentes gasosos e de poluentes de partículas	2016/1628/REGULAMENTO da UE
2011/65/UE como restrição diretiva alterada da utilização de certas substâncias perigosas em equipamentos elétricos e eletrônicos	
Measured Sound Power Level	Guaranteed Sound Power Level
Le niveau de puissance acoustique mesuré	Le niveau de puissance acoustique garant
Zmierzony poziom mocy akustycznej	Gwarantowany poziom mocy akustycznej
Nivel de putere acustică măsurat	Nivel de putere acustică garantat
Nivel de potencia sonora medido	Nivel de potencia sonora garantizado
Nível de potência sonora medido	Nível de potência sonora garantido
: 108.4 dB(A)	: 110 dB(A)
Engine Model	
Modèle de moteur	
Model silnika	
Modelul motorului	
Modelo de motor	
Modelo de motor	
: SL34G	

References to the relevant harmonised standards used or references to the other technical specifications in relation to which conformity is declared:

Références des normes harmonisées pertinentes appliquées, y compris la date de celles-ci, ou des autres spécifications techniques, y compris la date de celles-ci, par rapport auxquelles la conformité est déclarée: Odwołania do odnośnych norm zharmonizowanych, które zastosowano, wraz z datą normy, lub do innych specyfikacji technicznych, wraz z datą specyfikacji, w odniesieniu do których deklarowana jest zgodność: Trimiteri la standardele armonizate relevante folosite, inclusiv data standardului, sau trimiteri la celelalte specificații tehnice, inclusiv data specificațiilor, în legătură cu care se declară conformitatea:

Referencias a las normas armonizadas pertinentes utilizadas, incluidas las fechas de las normas, o referencias a las otras especificaciones técnicas, incluidas las fechas de las especificaciones, respecto a las cuales se declara la conformidad:

Referências às normas harmonizadas aplicáveis utilizadas, incluindo a data da norma, ou às outras especificações técnicas, incluindo a data da especificação, em relação às quais é declarada a conformidade:

EN ISO 11806-1:2011

EN ISO 10517:2019

EN ISO 11680-1:2021

EN ISO 14982:2009

EN ISO 3744:1995

The notified body TÜV SÜD Product service GmbH/ No. 0123, performed EC Type Examination and issued the certificate: No.M6A 106544 0060 Rev.00

L'organisme notifié TÜV SÜD Product service GmbH/ No. 0123 Nürnberg a effectué EC Type Examination et a établi le certificate : No. M6A 106544 0060 Rev.00

W stosownych przypadkach jednostka notyfikowana TÜV SÜD Product service GmbH/ No. 0123 Nürnberg przeprowadziła EC Type Examination i wydała certyfikat: No. M6A 106544 0060 Rev.00

Organismul notificat TÜV SÜD Product service GmbH/ No. 0123 Nürnberg a efectuat EC Type Examination și a emis certificatul: No. M6A 106544 0060 Rev.00

El organismo notificado TÜV SÜD Product service GmbH/ No. 0123, Nürnberg ha efectuado EC Type Examination y expide el certificado: No. M6A 106544 0060 Rev.00

O organismo notificado TÜV SÜD Product service GmbH/ No. 0123, Nürnberg efectuou EC Type Examination e emitiu o certificado: No. M6A 106544 0060 Rev.00

Authorised signatory and technical file holder/signataire et responsable de la documentation technique autorisé/ podmiot uprawniony do wystawienia i adres przechowywania dokumentacji technicznej/semnatar autorizat și deținător al dosarului tehnic/firmante autorizado y titular del expediente tecnico/ signatário autorizado e detentor da ficha técnica

Kingfisher International Products B.V.,  
Rapenburgerstraat 175E,  
1011 VM Amsterdam,  
The Netherlands

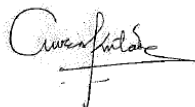

David Awe  
Group Quality Director

: 04/05/2022

# TITAN

**Manufacturer, Fabricant, Prodecnt,  
Producător, Fabricante:**

**UK Manufacturer:**

Kingfisher International Products Limited  
3 Sheldon Square London W2 6PX  
United Kingdom

**EU Manufacturer:**

Kingfisher International Products B.V.  
Rapenburgerstraat 175E 1011 VM Amsterdam  
The Netherlands

**EN** [www.diy.com](http://www.diy.com)  
[www.screwfix.com](http://www.screwfix.com)  
[www.screwfix.ie](http://www.screwfix.ie)

To view instruction manuals online,  
visit [www.kingfisher.com/products](http://www.kingfisher.com/products)